

AppliCad Software Inc

6/70 Railway Road
Blackburn 3130
Email: usasales@applicad.com
Phone: +61 3 9878 5000
Fax: +61 3 9878 5055
16 June 2011



Solar Panel Proposal

Order Number: O3245

Details

Customer Information:

Joe Bloggs
143 High Street
Chicago, IL
Phone: 256 569 5698
Email: joe@chicago.net

Installer Information:

Fred Chaplin
24 Big Road,
St. Andrews
Phone: 07 8899663
Email: fred@applicad.com

Property Locator

Longitude: 87.7345 Latitude 41.7458

Web Map Location: <http://www.bing.com/roofpic.html/roofpics/moreroofs>

Roof Plan View - (dimensions in feet or metres; areas in SqFt or SqM)

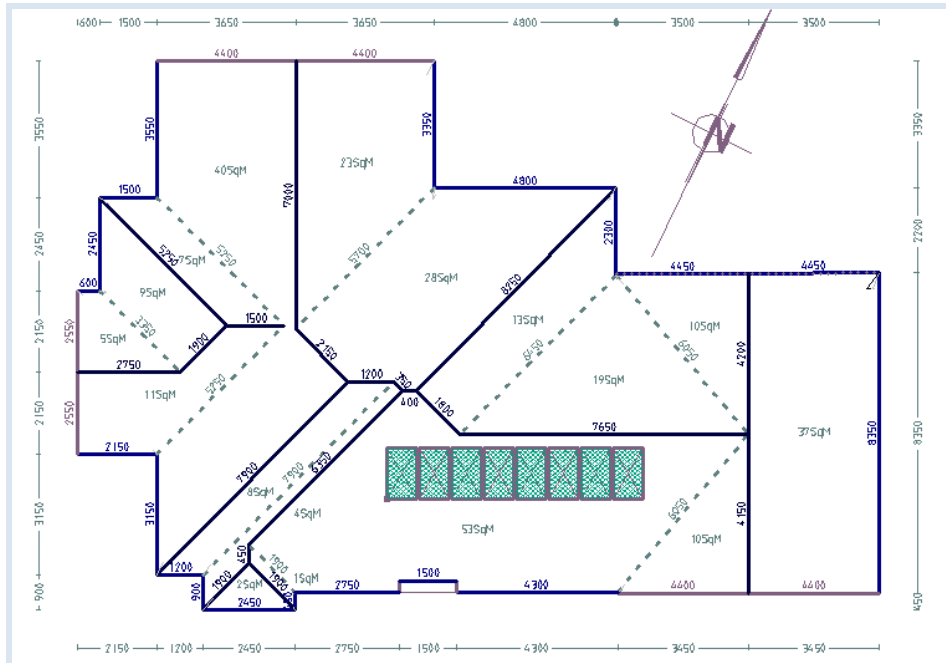

AppliCad Software Inc

6/70 Railway Road
Blackburn 3130
Email: usasales@applicad.com
Phone: +61 3 9878 5000
Fax: +61 3 9878 5055
16 June 2011



Solar Panel Proposal

Order Number: O3245

Fixture Exclusion Zones

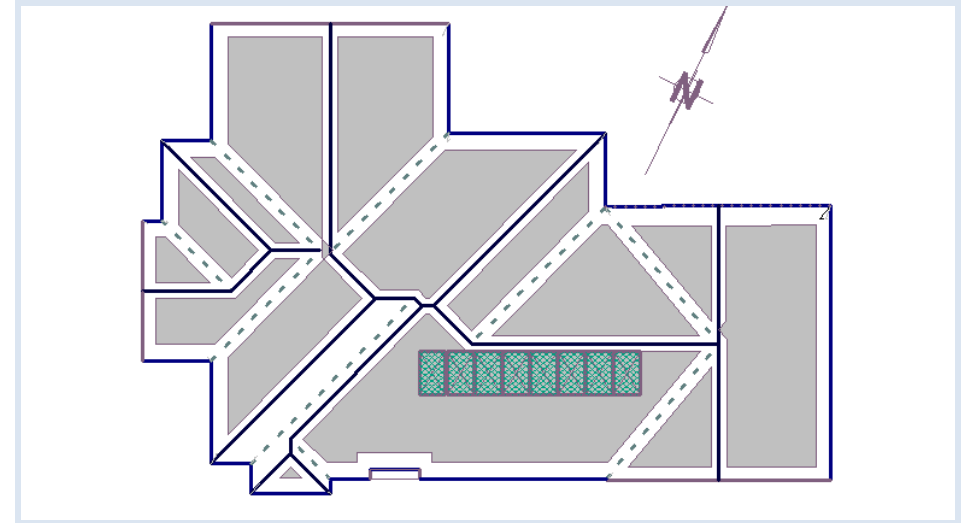

Aerial Photos - Overhead View



AppliCad Software Inc

6/70 Railway Road
Blackburn 3130
Email: usasales@appliCad.com
Phone: +61 3 9878 5000
Fax: +61 3 9878 5055
16 June 2011



Solar Panel Proposal

Order Number: O3245

Oblique Aerial Photos



North Side View

South Side View



East Side View

West Side View

AppliCad Software Inc

6/70 Railway Road
Blackburn 3130
Email: usasales@appliCad.com
Phone: +61 3 9878 5000
Fax: +61 3 9878 5055
16 June 2011



Solar Panel Proposal

Order Number: O3245

Roof Plane Pitch - (Degrees, Slope or Percentage)

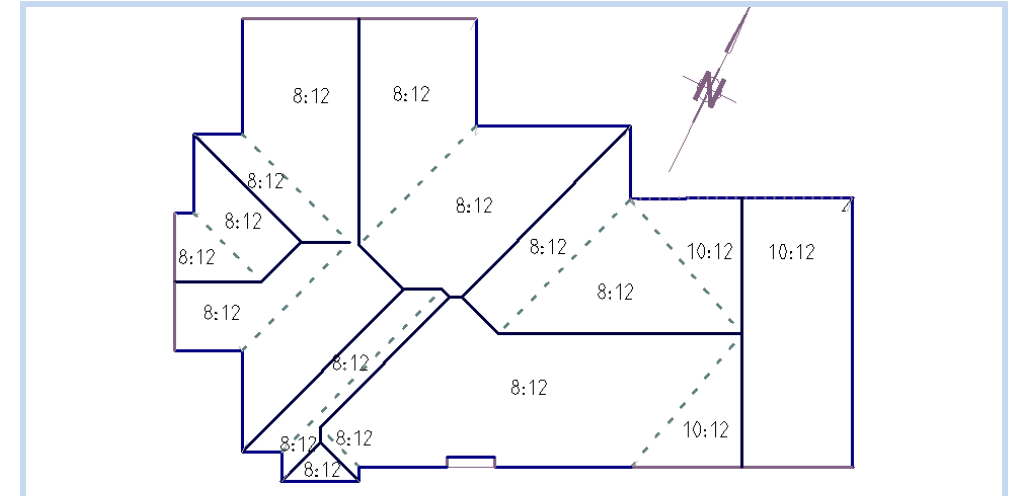

Shadow Map - (For Solstice (winter shown) or Annual Range)

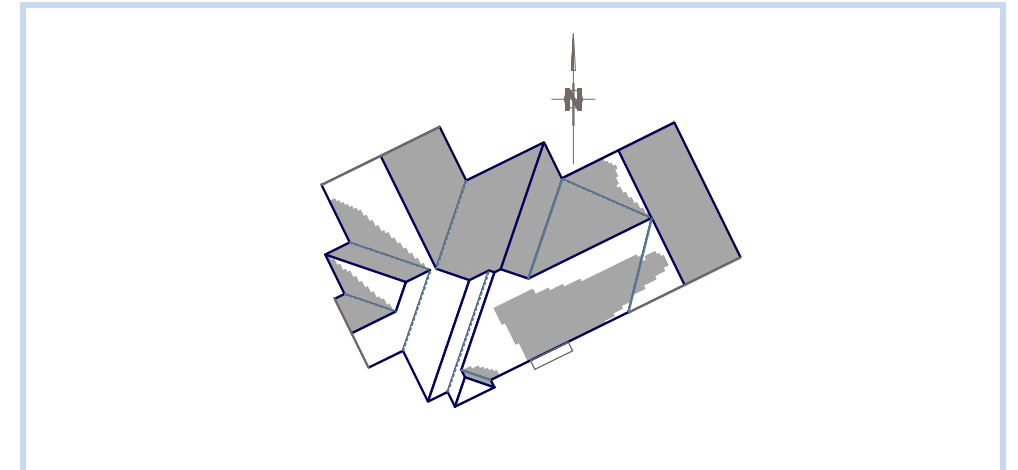

AppliCad Software Inc

6/70 Railway Road
 Blackburn 3130
 Email: usasales@applicad.com
 Phone: +61 3 9878 5000
 Fax: +61 3 9878 5055
 16 June 2011



Solar Panel Proposal

Order Number: O3245

Insolation Map - Red to White range - Winter

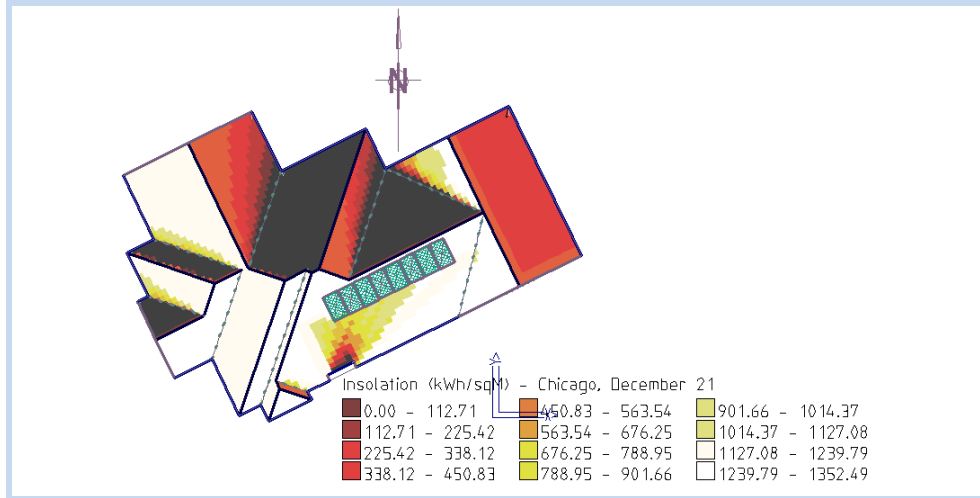

Insolation Map - Red to White range - Summer

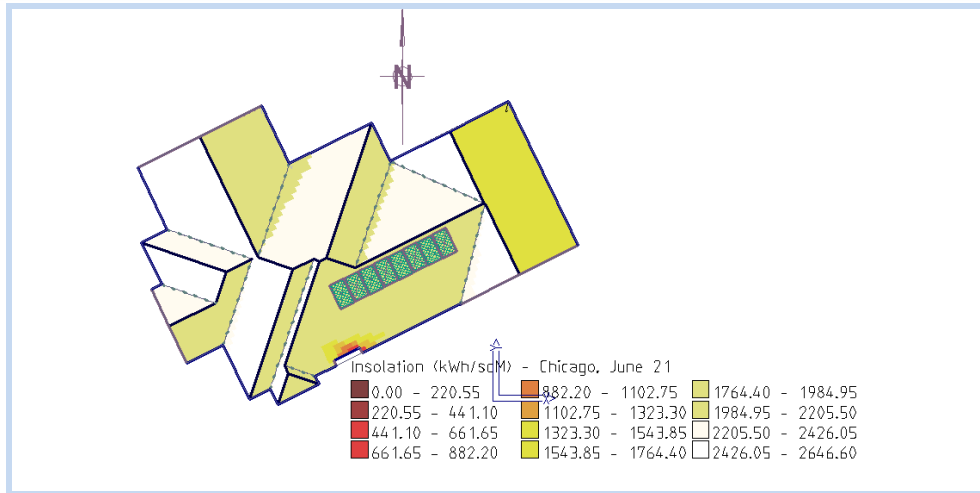

AppliCad Software Inc

6/70 Railway Road
 Blackburn 3130
 Email: usasales@applicad.com
 Phone: +61 3 9878 5000
 Fax: +61 3 9878 5055
 16 June 2011



Solar Panel Proposal

Order Number: O3245

Order Summary

Category	Item Description	Qty	Rate	SubTotal	Total
Package	Standard Domestic 'WattSaver' package				2599.00
Fixtures	8 x 190 Watt Mono Crystalline PV Panels		0.00	0.00	0.00
Inverter	1 x 2.0 Kw Growatt Inverter		0.00	0.00	0.00
Fittings	All fittings and rails included		0.00	0.00	0.00
Cabling	All cables and ties included		0.00	0.00	0.00
	Travel				0.00
	Roof				0.00
	Asbestos				0.00
	Storey				0.00
	Discount				0.00
	Job Total (excl Tax)				2599.00
	Required Deposit				1000.00
	Paid				0.00
	Balance Due				2599.00
Site	Pitched roof	<30°			
Details	Asbestos	no			
	Stories	single			
	Switchboard	external	>20yrs		
	Electrical	Cct Bkr			
	Travel	1 - 5miles			
	Smartmeter	n/a			
	Home Owner	yes			
Production	System production per day average	5.38 x 1.65	365		3240.10
Indication					Kw/year
	Average household use	3Kw			
	Savings				
	3Kw x (market rate per Kw)	0.96 c day			
	Yearly savings	\$265.65			
	ROI - 10.2% on initial investment				

Roof Grid - 'As Built' Planning Grid

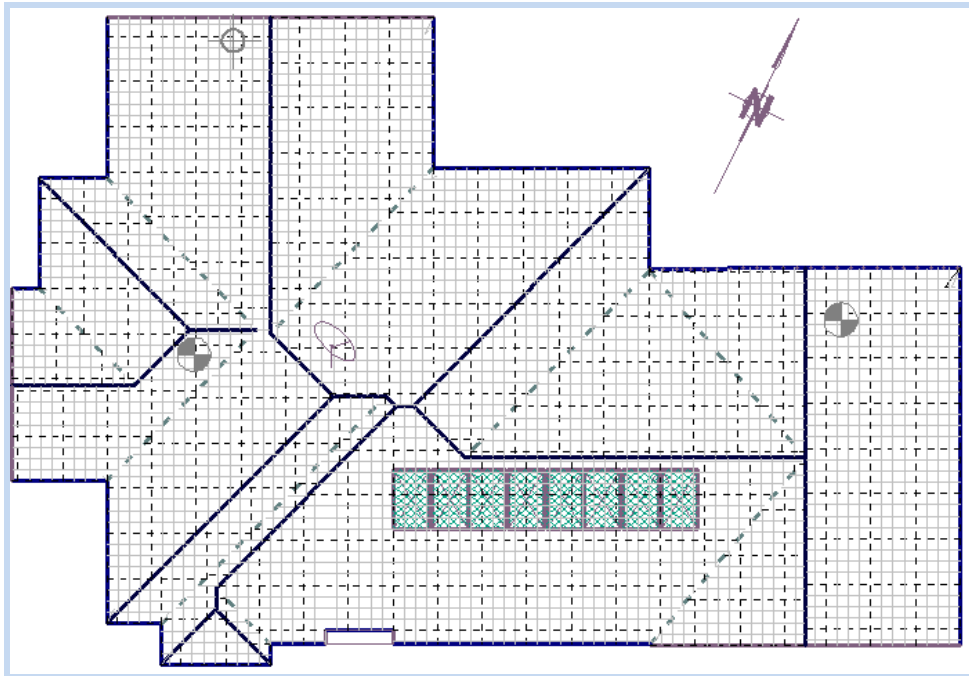

Client: Joe Bloggs **Job Address:** 24 Big Road, St. Andrews.

Site Inspection Notes:

Site has difficult access. Crane and travel lift required. Some restoration of roof substrate to be arranged and paid for by the owner.

BEWARE OF OWNERS DOG. IT IS BIG!

Insolation Map - (showing effects of external influences such as buildings & trees)

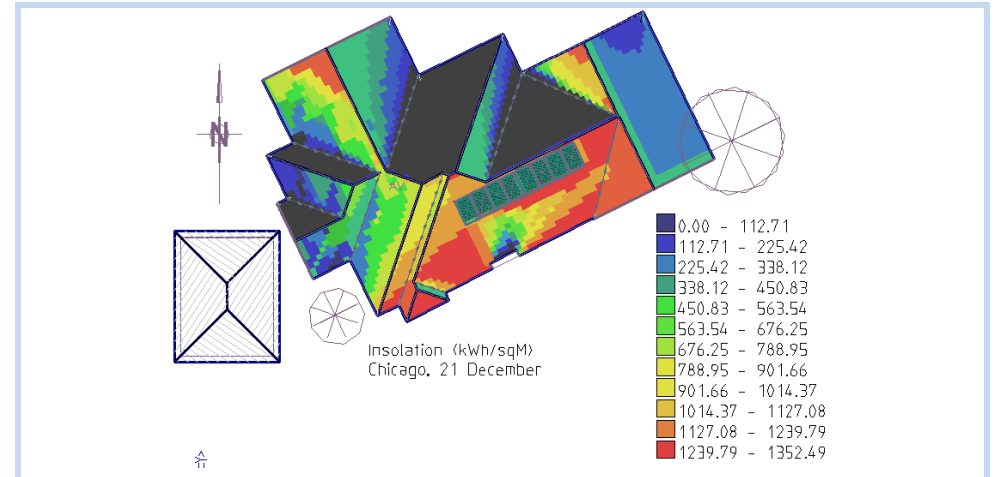

Roof Plane Azimuth Angles

