

# Estimate For



**New Mart Builders Inc.**

1000 Cycle Lane  
South Hill VA 23970  
Email: bob.davis@newmartbuilder.com  
Phone: 434-584-0027  
**Date: 16 December 2016**



## Roof Take-Off

**Job: TCD Summerwood**

### Job Name : TCD Summerwood

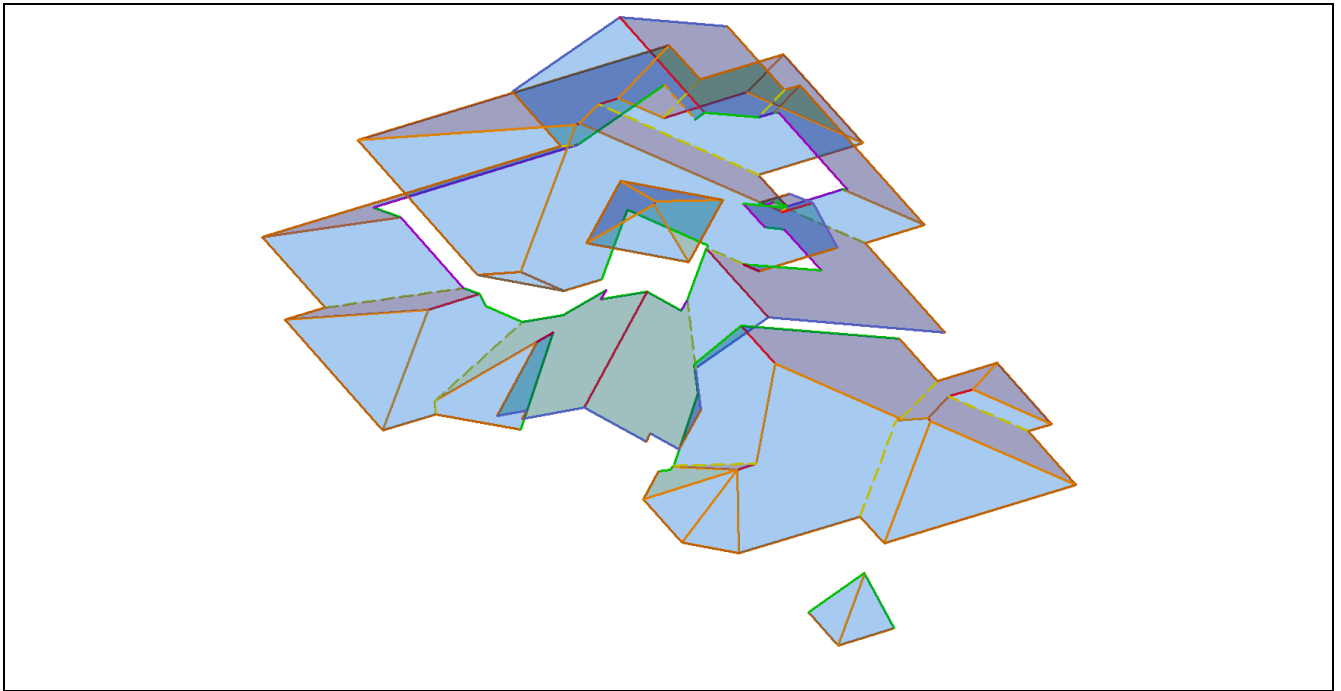

**Panel Material(s)**

Standard, SS NAIL STRIP, Standing Seam, PVDF, 24.00, 16.0

**Panel Length(s)**

5092.83

**Panel Area(s)**

6790.44

**Panel Quantity(s)**

567 panels

**Total Roof Area**

5940.28 ft<sup>2</sup>

# Estimate For



New Mart Builders Inc.

1000 Cycle Lane  
South Hill VA 23970

Email: bob.davis@newmartbuilder.com

Phone: 434-584-0027

Date: 16 December 2016



## Roof Take-Off

Job: TCD Summerwood

### SECTION REPORT

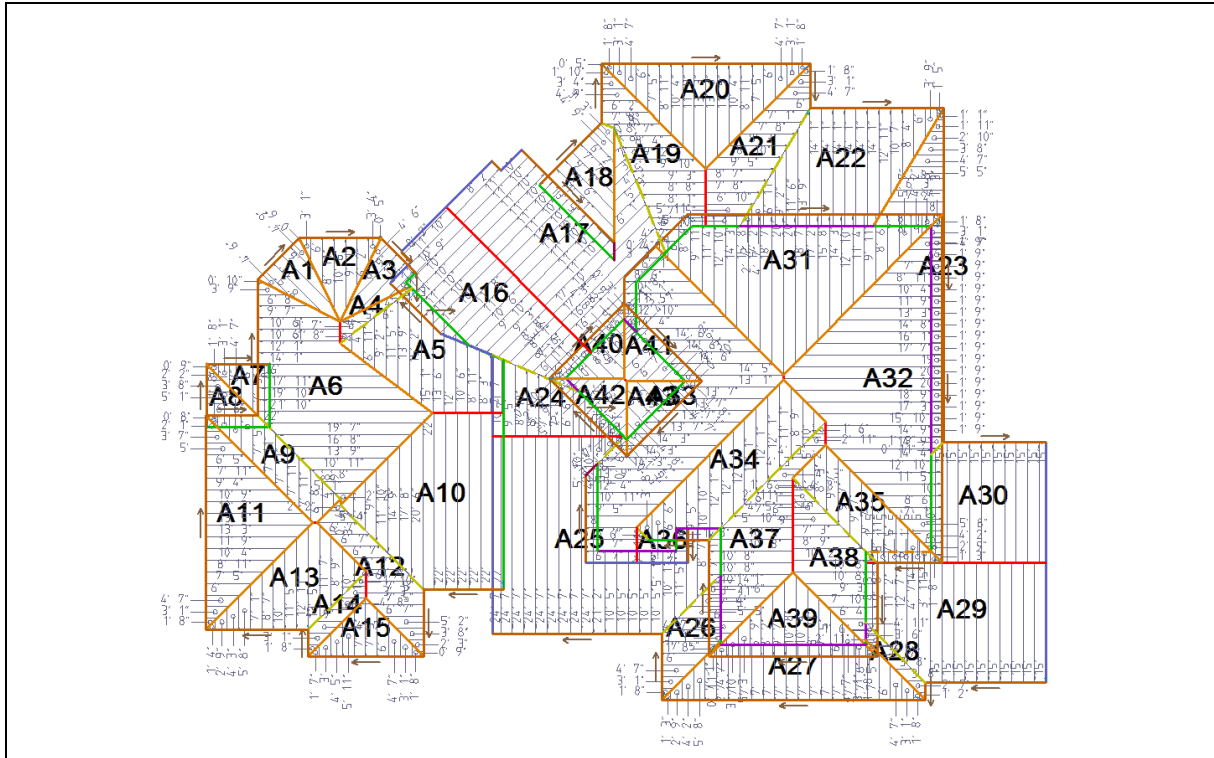

Section A - SS NAIL STRIP, Standing Seam, PVDF, 24 Ga.  
Surface Area = 5940.28 Sq. Ft.

# Estimate For



**New Mart Builders Inc.**

1000 Cycle Lane  
 South Hill VA 23970  
 Email: bob.davis@newmartbuilder.com  
 Phone: 434-584-0027  
**Date: 16 December 2016**



## Roof Take-Off

**Job: TCD Summerwood**

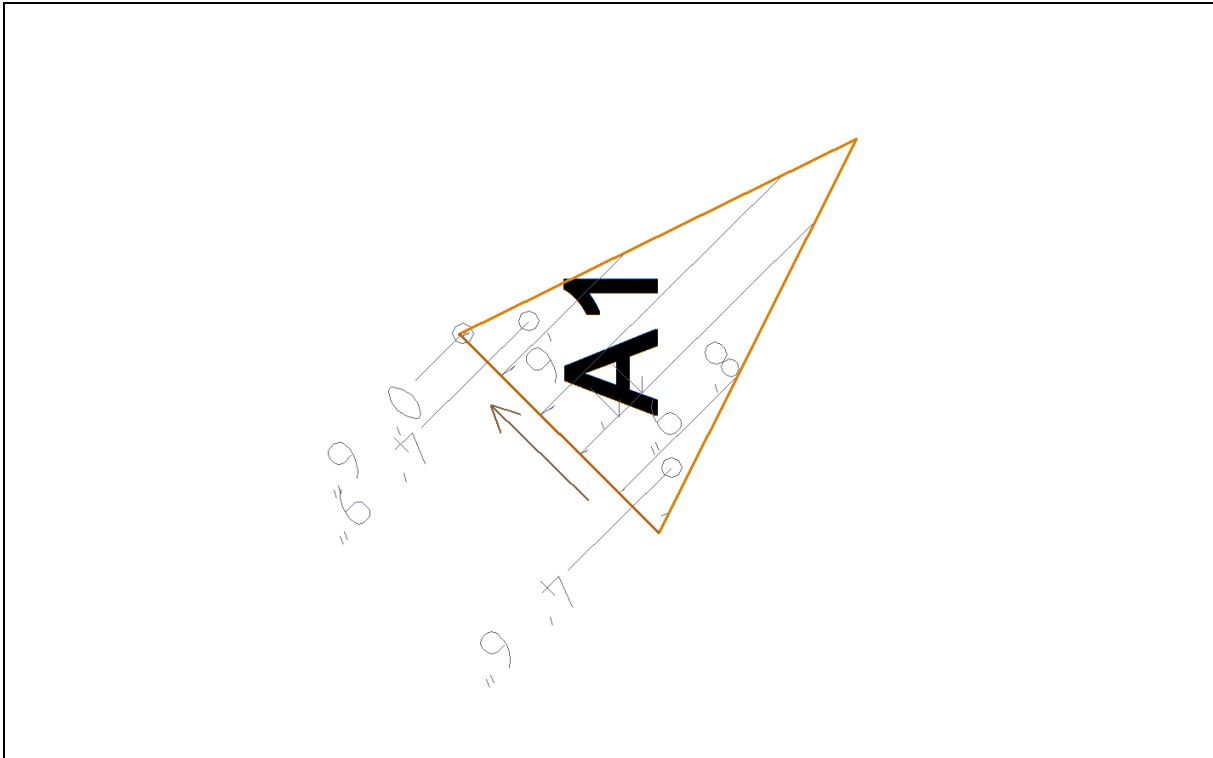

Plane A1 - 36.39 Sq. Ft.

Qty	Linear Feet	Total Lin. Feet	Qty	Linear Feet	Total Lin. Feet
1	11' 0"	11' 0"	1	4' 9"	4' 9"
1	9' 0"	9' 0"	1	4' 6"	4' 6"
1	8' 9"	8' 9"	1	3' 0"	3' 0"
<b>SubTotal</b>	6	Panels			41' 0"

**Minimum Panel Length Breakdown**

1 / 3' above made up of 1/0' 6".

# Estimate For



**New Mart Builders Inc.**

1000 Cycle Lane  
 South Hill VA 23970  
 Email: bob.davis@newmartbuilder.com  
 Phone: 434-584-0027  
**Date: 16 December 2016**



## Roof Take-Off

**Job: TCD Summerwood**

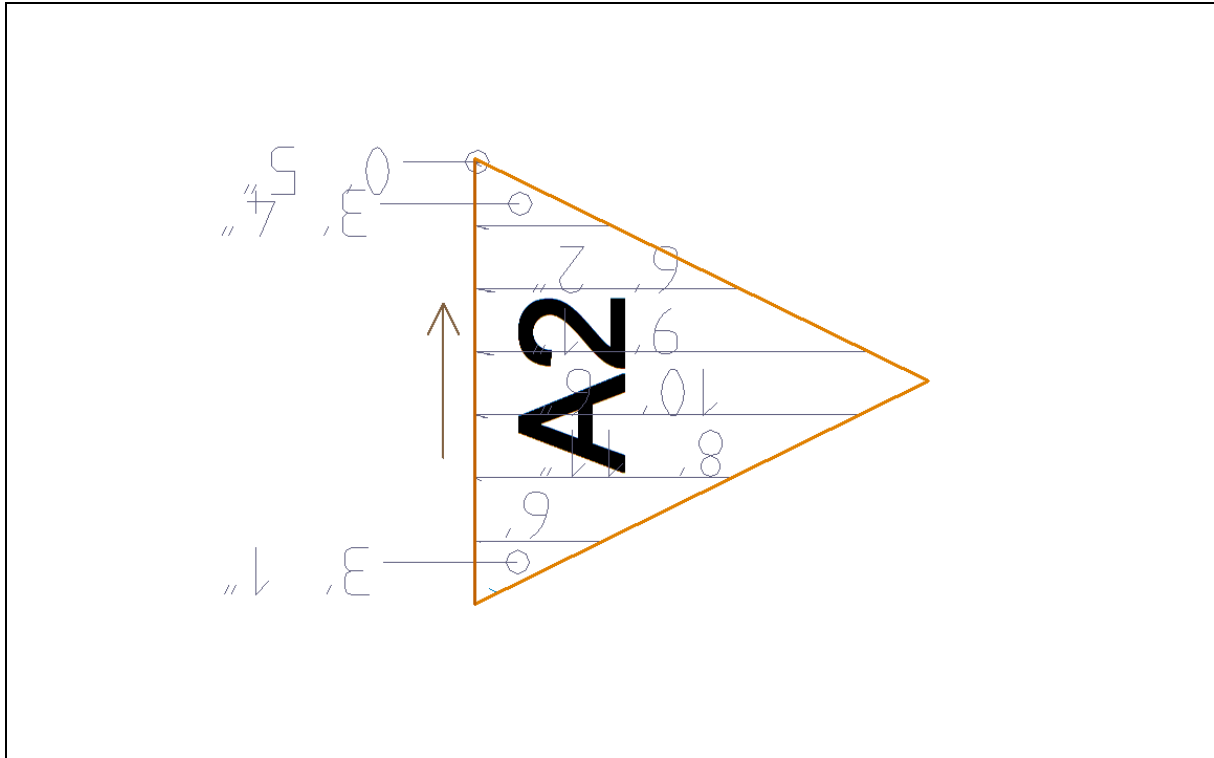

Plane A2 - 48.36 Sq. Ft.

Qty	Linear Feet	Total Lin. Feet	Qty	Linear Feet	Total Lin. Feet
1	10' 6"	10' 6"	1	6' 0"	6' 0"
1	9' 1"	9' 1"	1	3' 4"	3' 4"
1	8' 11"	8' 11"	1	3' 1"	3' 1"
1	6' 2"	6' 2"	1	3' 0"	3' 0"
<b>SubTotal</b>	8	Panels			50' 1"

**Minimum Panel Length Breakdown**

1 / 3' above made up of 1/0' 5".

# Estimate For



**New Mart Builders Inc.**

1000 Cycle Lane  
 South Hill VA 23970  
 Email: bob.davis@newmartbuilder.com  
 Phone: 434-584-0027  
**Date: 16 December 2016**



## Roof Take-Off

**Job: TCD Summerwood**

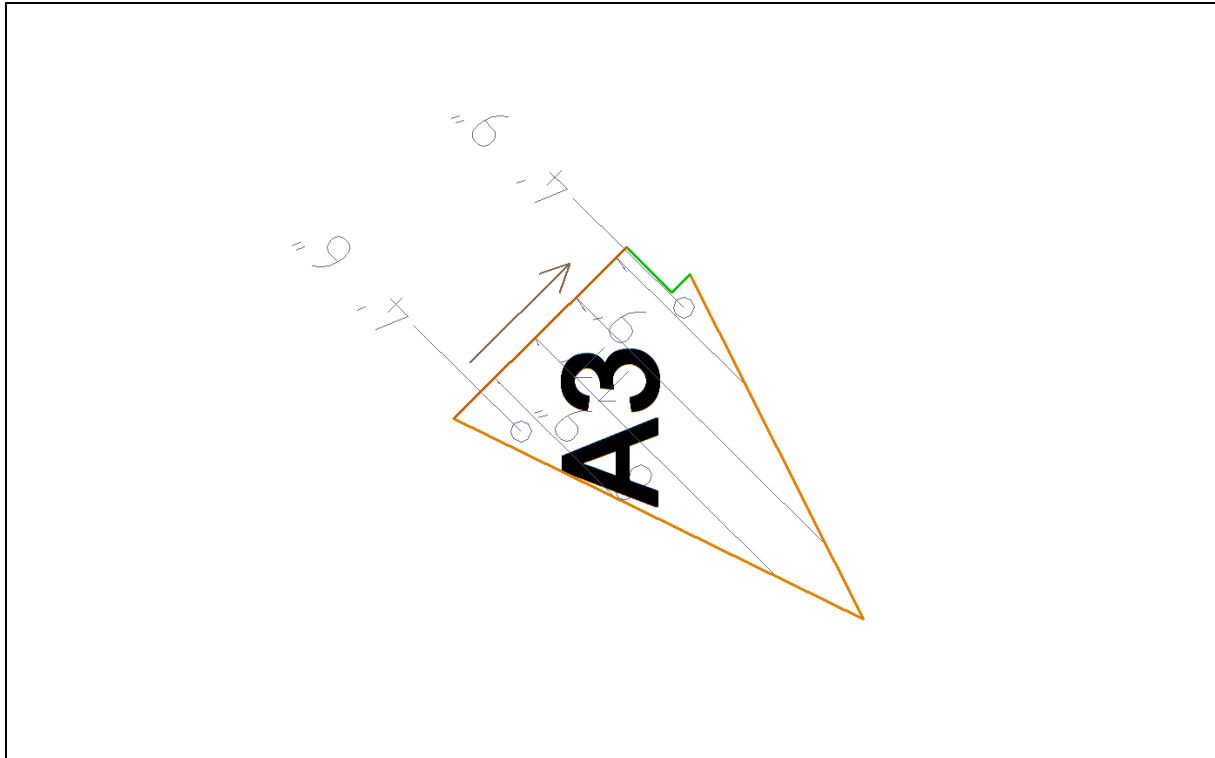

Plane A3 - 35.04 Sq. Ft.

Qty	Linear Feet	Total Lin. Feet	Qty	Linear Feet	Total Lin. Feet
1	11' 0"	11' 0"	1	4' 9"	4' 9"
1	9' 0"	9' 0"	1	4' 6"	4' 6"
1	8' 9"	8' 9"			
<b>SubTotal</b>	5	Panels			38' 0"

# Estimate For



**New Mart Builders Inc.**

1000 Cycle Lane  
 South Hill VA 23970  
 Email: bob.davis@newmartbuilder.com  
 Phone: 434-584-0027  
**Date: 16 December 2016**



## Roof Take-Off

**Job: TCD Summerwood**

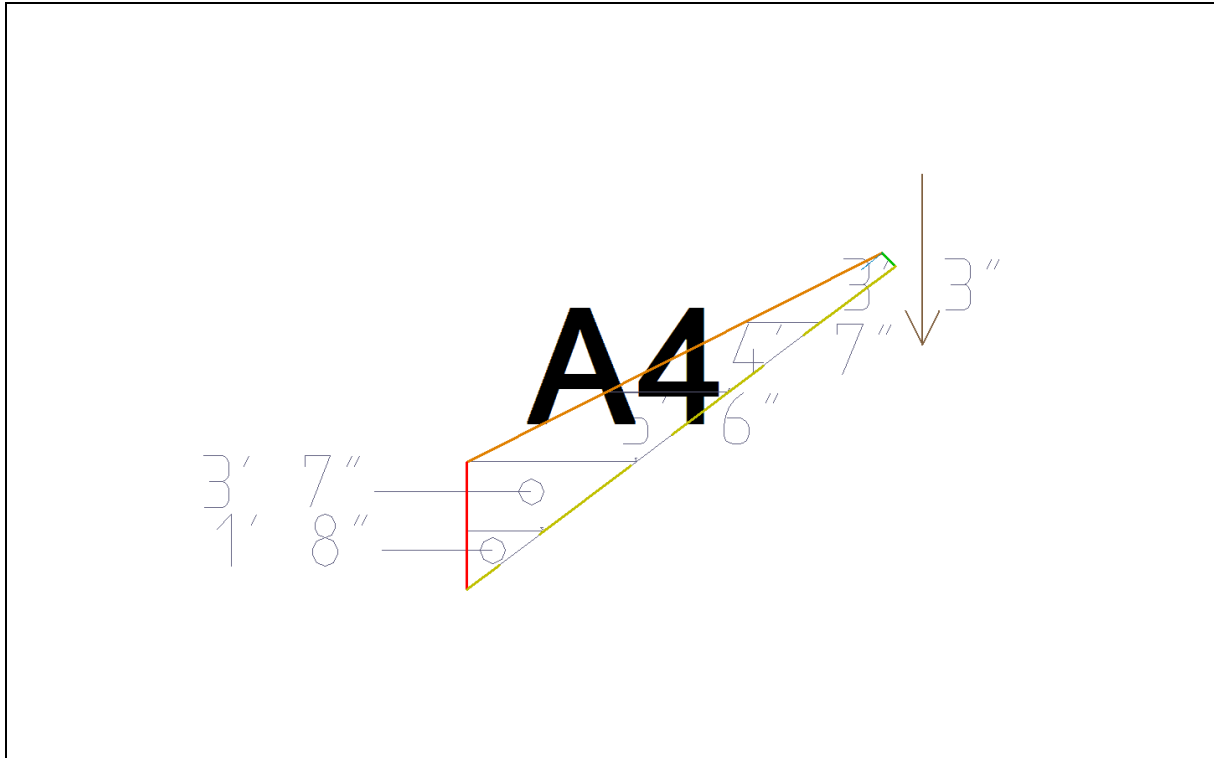

Plane A4 - 12.68 Sq. Ft.

Qty	Linear Feet	Total Lin. Feet	Qty	Linear Feet	Total Lin. Feet
1	5' 6"	5' 6"	1	3' 3"	3' 3"
1	4' 7"	4' 7"	1	3' 0"	3' 0"
1	3' 7"	3' 7"			
<b>SubTotal</b>	5	Panels			19' 11"

**Minimum Panel Length Breakdown**

1 / 3' above made up of 1/1' 8".

# Estimate For



**New Mart Builders Inc.**

1000 Cycle Lane  
 South Hill VA 23970  
 Email: bob.davis@newmartbuilder.com  
 Phone: 434-584-0027  
**Date: 16 December 2016**



## Roof Take-Off

**Job: TCD Summerwood**

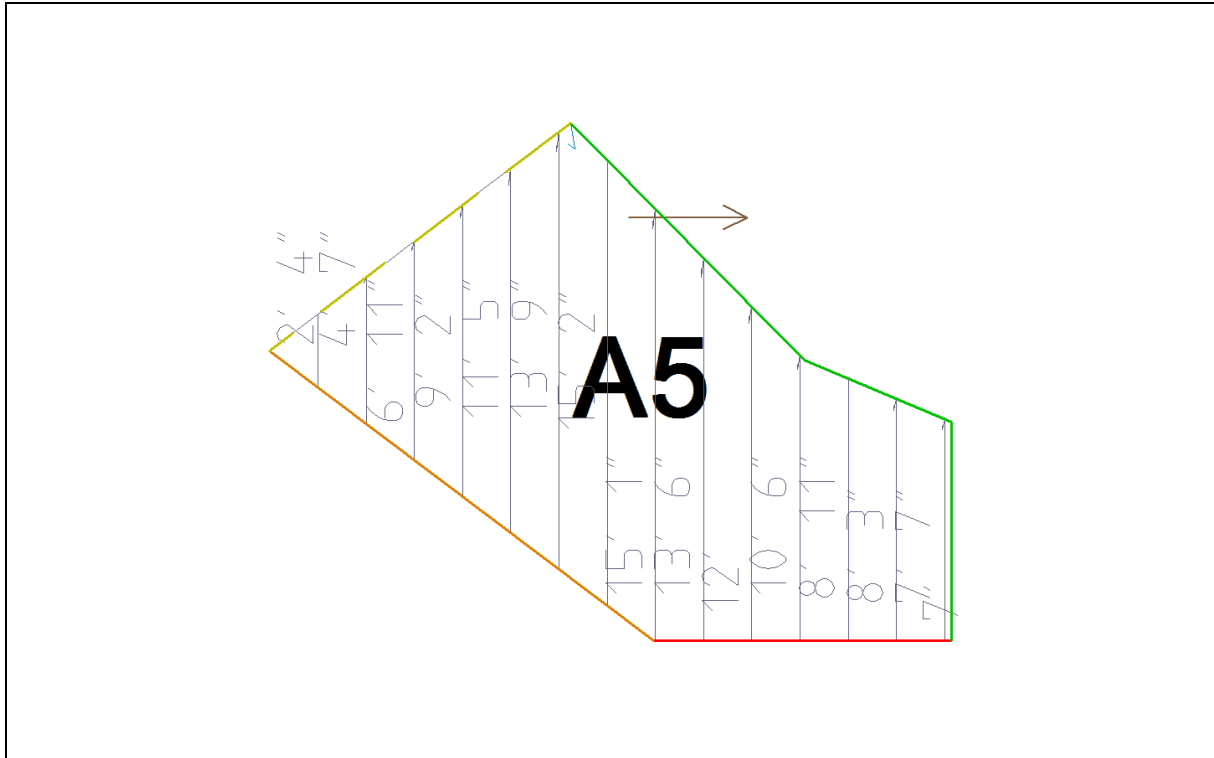

Plane A5 - 169.36 Sq. Ft.

Qty	Linear Feet	Total Lin. Feet	Qty	Linear Feet	Total Lin. Feet
1	15' 2"	15' 2"	1	8' 11"	8' 11"
1	15' 1"	15' 1"	1	8' 3"	8' 3"
1	13' 9"	13' 9"	1	7' 7"	7' 7"
1	13' 6"	13' 6"	1	7' 0"	7' 0"
1	12' 0"	12' 0"	1	6' 11"	6' 11"
1	11' 5"	11' 5"	1	4' 7"	4' 7"
1	10' 6"	10' 6"	1	3' 0"	3' 0"
1	9' 2"	9' 2"			
<b>SubTotal</b>	15	Panels			146' 10"

**Minimum Panel Length Breakdown**

1 / 3' above made up of 1/2' 4".

# Estimate For



**New Mart Builders Inc.**

1000 Cycle Lane  
 South Hill VA 23970  
 Email: bob.davis@newmartbuilder.com  
 Phone: 434-584-0027  
 Date: 16 December 2016



## Roof Take-Off

Job: TCD Summerwood

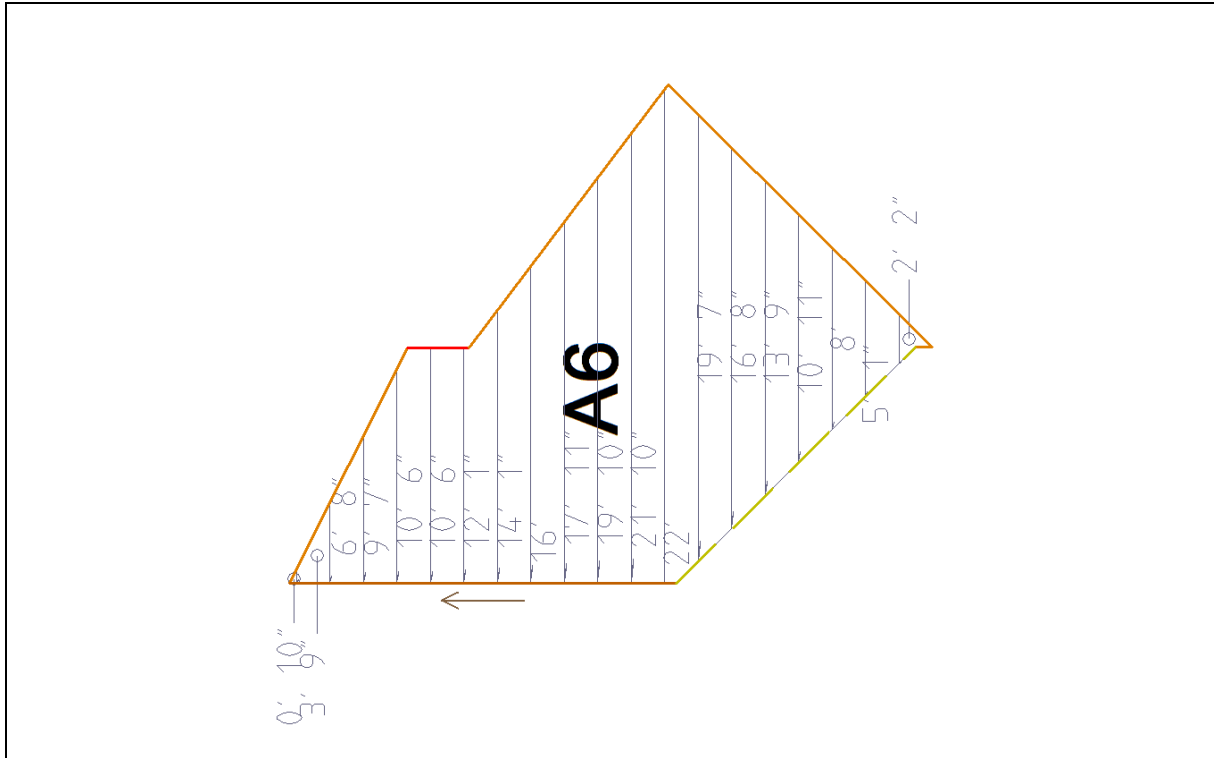

Plane A6 - 289.28 Sq. Ft.

Qty	Linear Feet	Total Lin. Feet	Qty	Linear Feet	Total Lin. Feet
1	22' 0"	22' 0"	1	12' 1"	12' 1"
1	21' 10"	21' 10"	1	10' 11"	10' 11"
1	19' 10"	19' 10"	2	10' 6"	21' 0"
1	19' 7"	19' 7"	1	9' 7"	9' 7"
1	17' 11"	17' 11"	1	8' 0"	8' 0"
1	16' 8"	16' 8"	1	6' 8"	6' 8"
1	16' 0"	16' 0"	1	5' 1"	5' 1"
1	14' 1"	14' 1"	1	3' 9"	3' 9"
1	13' 9"	13' 9"	1	3' 1"	3' 1"
<b>SubTotal</b>	19	Panels			241' 10"

**Minimum Panel Length Breakdown**

1 / 3' 1" above made up of 1/2' 2", 1/0' 10".



# Estimate For



**New Mart Builders Inc.**

1000 Cycle Lane  
 South Hill VA 23970  
 Email: bob.davis@newmartbuilder.com  
 Phone: 434-584-0027  
**Date: 16 December 2016**



## Roof Take-Off

**Job: TCD Summerwood**

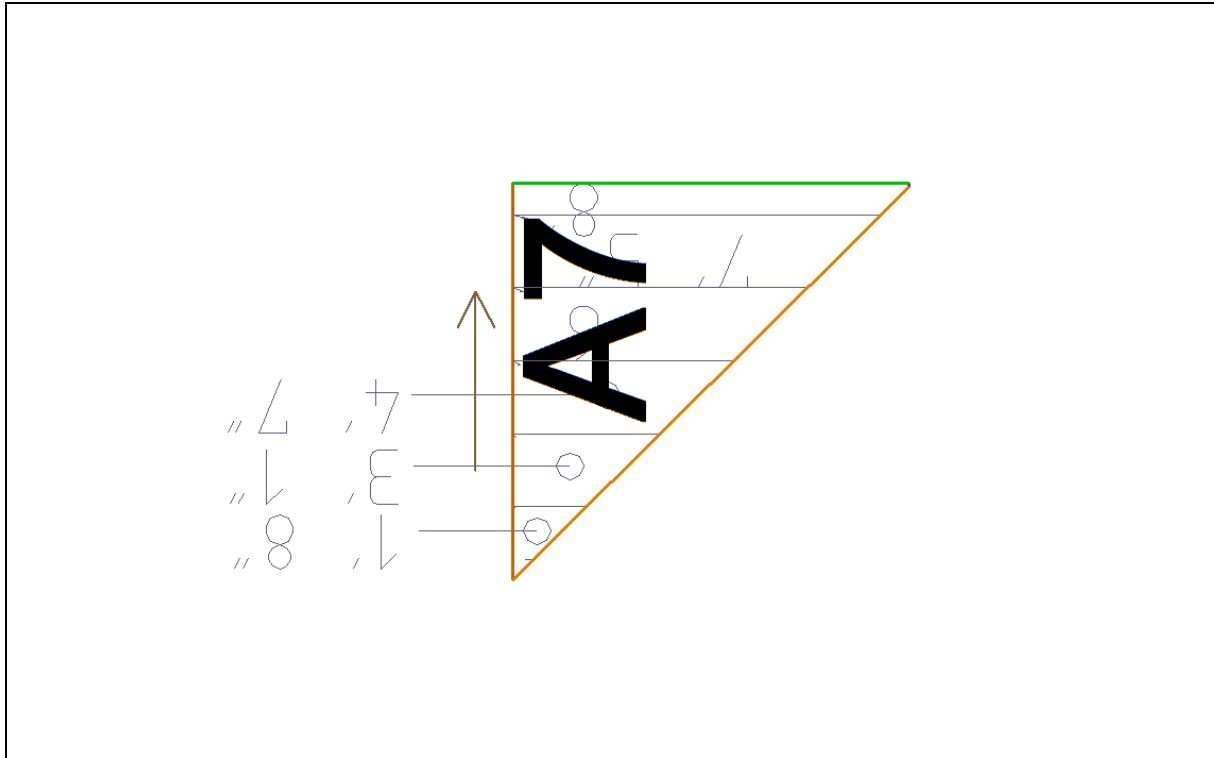

Plane A7 - 28.47 Sq. Ft.

Qty	Linear Feet	Total Lin. Feet	Qty	Linear Feet	Total Lin. Feet
1	8' 0"	8' 0"	1	4' 7"	4' 7"
1	7' 5"	7' 5"	1	3' 1"	3' 1"
1	6' 0"	6' 0"	1	3' 0"	3' 0"
<b>SubTotal</b>	6	Panels			32' 1"

**Minimum Panel Length Breakdown**

1 / 3' above made up of 1/1' 8".

# Estimate For



**New Mart Builders Inc.**

1000 Cycle Lane  
 South Hill VA 23970  
 Email: bob.davis@newmartbuilder.com  
 Phone: 434-584-0027  
**Date: 16 December 2016**



## Roof Take-Off

**Job: TCD Summerwood**

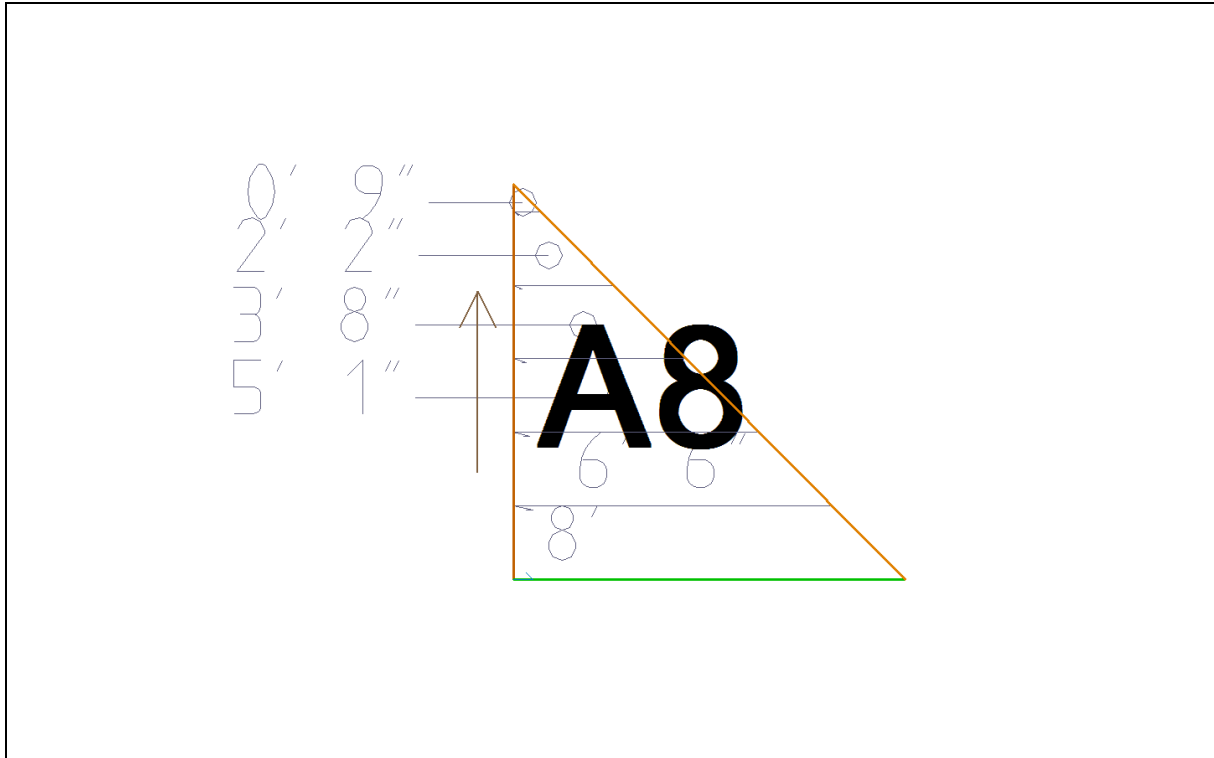

Plane A8 - 27.82 Sq. Ft.

Qty	Linear Feet	Total Lin. Feet	Qty	Linear Feet	Total Lin. Feet
1	8' 0"	8' 0"	1	3' 8"	3' 8"
1	6' 6"	6' 6"	1	3' 0"	3' 0"
1	5' 1"	5' 1"			
<b>SubTotal</b>	5	Panels			26' 3"

**Minimum Panel Length Breakdown**

1 / 3' above made up of 1/2' 2", 1/0' 9".

# Estimate For



**New Mart Builders Inc.**

1000 Cycle Lane  
 South Hill VA 23970  
 Email: bob.davis@newmartbuilder.com  
 Phone: 434-584-0027  
**Date: 16 December 2016**



## Roof Take-Off

**Job: TCD Summerwood**

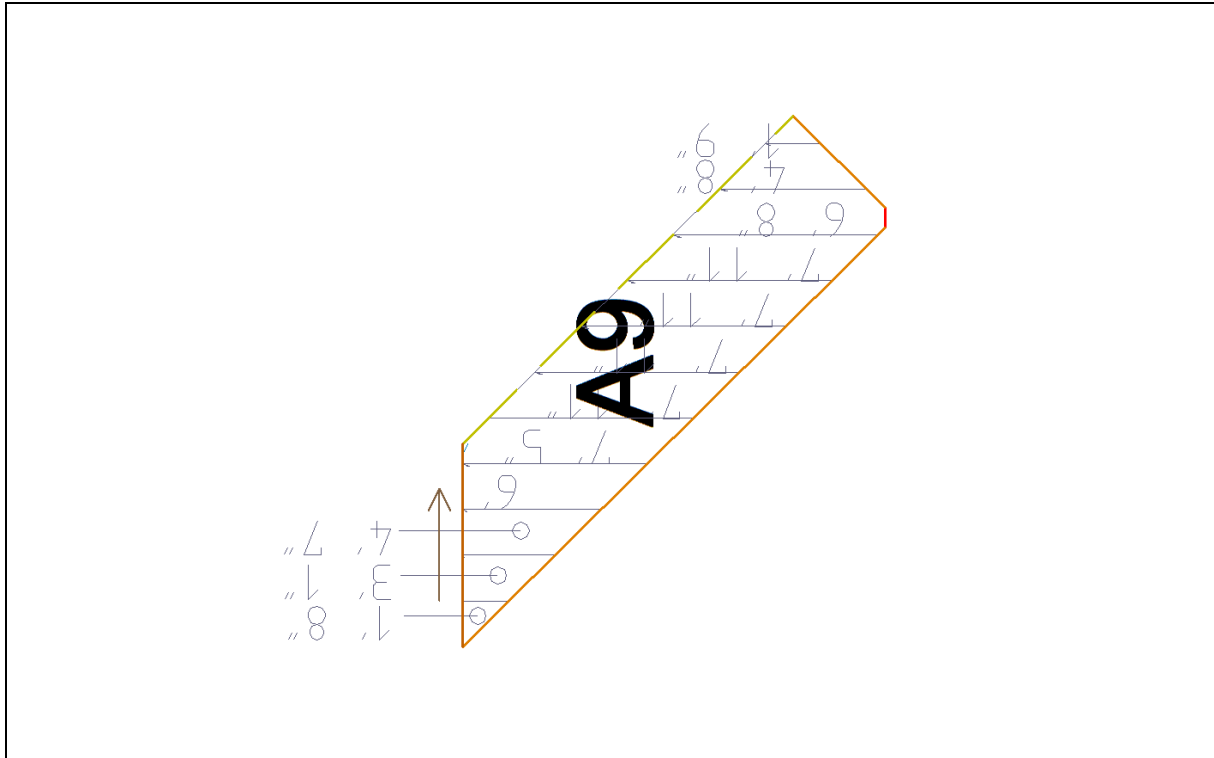

Plane A9 - 70.55 Sq. Ft.

Qty	Linear Feet	Total Lin. Feet	Qty	Linear Feet	Total Lin. Feet
4	7' 11"	31' 8"	1	4' 8"	4' 8"
1	7' 5"	7' 5"	1	4' 7"	4' 7"
1	6' 8"	6' 8"	1	3' 5"	3' 5"
1	6' 0"	6' 0"	1	3' 1"	3' 1"
<b>SubTotal</b>	11	Panels			67' 6"

**Minimum Panel Length Breakdown**

1 / 3' 5" above made up of 1/1' 9", 1/1' 8".

# Estimate For



**New Mart Builders Inc.**

1000 Cycle Lane  
 South Hill VA 23970  
 Email: bob.davis@newmartbuilder.com  
 Phone: 434-584-0027  
**Date: 16 December 2016**



## Roof Take-Off

**Job: TCD Summerwood**

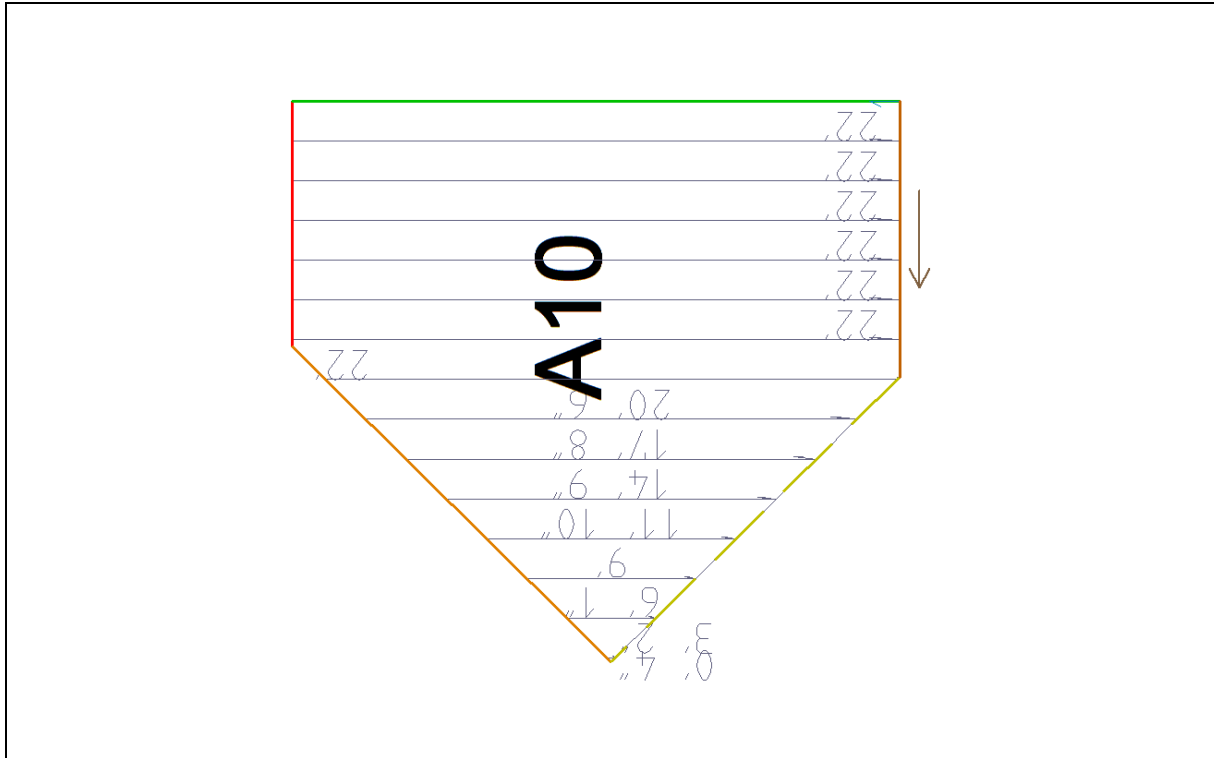

Plane A10 - 299.40 Sq. Ft.

Qty	Linear Feet	Total Lin. Feet	Qty	Linear Feet	Total Lin. Feet
7	22' 0"	154' 0"	1	9' 0"	9' 0"
1	20' 6"	20' 6"	1	6' 1"	6' 1"
1	17' 8"	17' 8"	1	3' 2"	3' 2"
1	14' 9"	14' 9"	1	3' 0"	3' 0"
1	11' 10"	11' 10"			
<b>SubTotal</b>	15	Panels			240' 0"

**Minimum Panel Length Breakdown**

1 / 3' above made up of 1/0' 4".

# Estimate For



**New Mart Builders Inc.**

1000 Cycle Lane  
 South Hill VA 23970  
 Email: bob.davis@newmartbuilder.com  
 Phone: 434-584-0027  
 Date: 16 December 2016



## Roof Take-Off

Job: TCD Summerwood

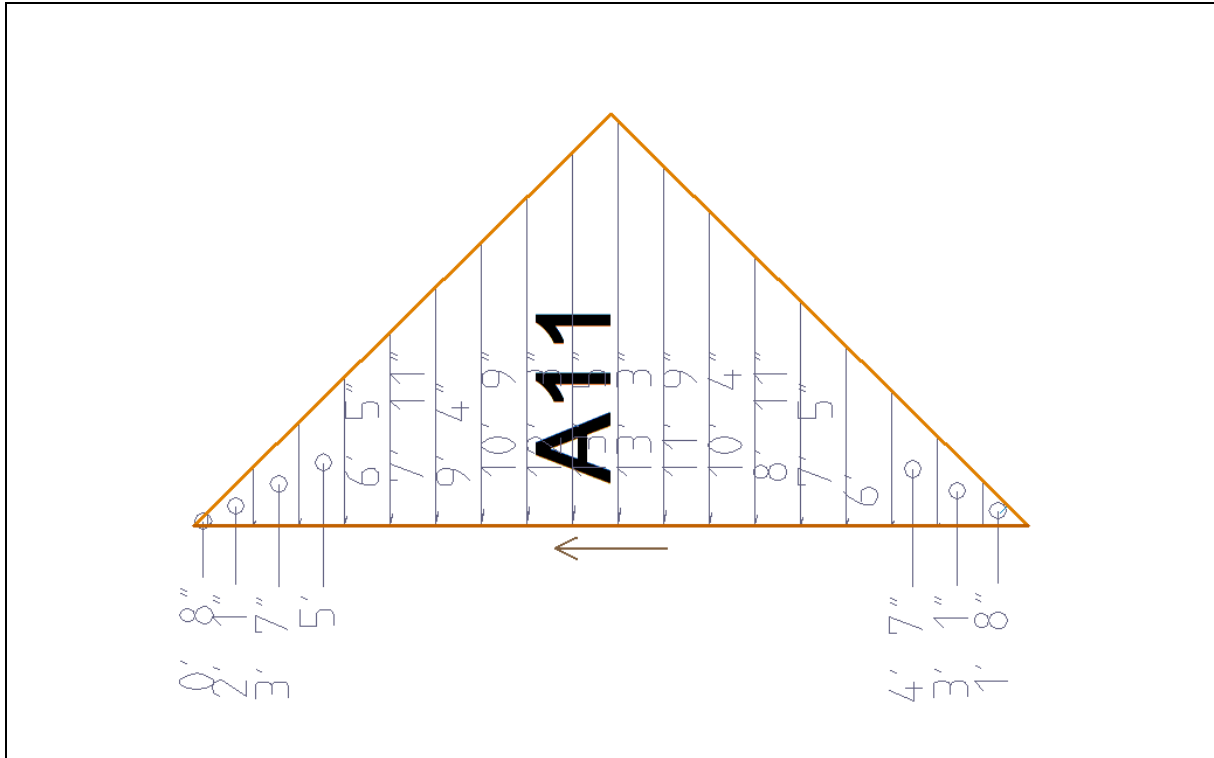

Plane A11 - 161.46 Sq. Ft.

Qty	Linear Feet	Total Lin. Feet	Qty	Linear Feet	Total Lin. Feet
1	13' 5"	13' 5"	1	7' 5"	7' 5"
1	13' 3"	13' 3"	1	6' 5"	6' 5"
1	12' 3"	12' 3"	1	6' 0"	6' 0"
1	11' 9"	11' 9"	1	5' 0"	5' 0"
1	10' 9"	10' 9"	1	4' 7"	4' 7"
1	10' 4"	10' 4"	1	3' 9"	3' 9"
1	9' 4"	9' 4"	1	3' 7"	3' 7"
1	8' 11"	8' 11"	1	3' 1"	3' 1"
1	7' 11"	7' 11"	1	3' 0"	3' 0"
<b>SubTotal</b>	18	Panels			140' 9"

**Minimum Panel Length Breakdown**

1 / 3' 9" above made up of 1/2' 1", 1/1' 8".

1 / 3' above made up of 1/0' 8".

# Estimate For



**New Mart Builders Inc.**

1000 Cycle Lane  
 South Hill VA 23970  
 Email: bob.davis@newmartbuilder.com  
 Phone: 434-584-0027  
**Date: 16 December 2016**



## Roof Take-Off

**Job: TCD Summerwood**

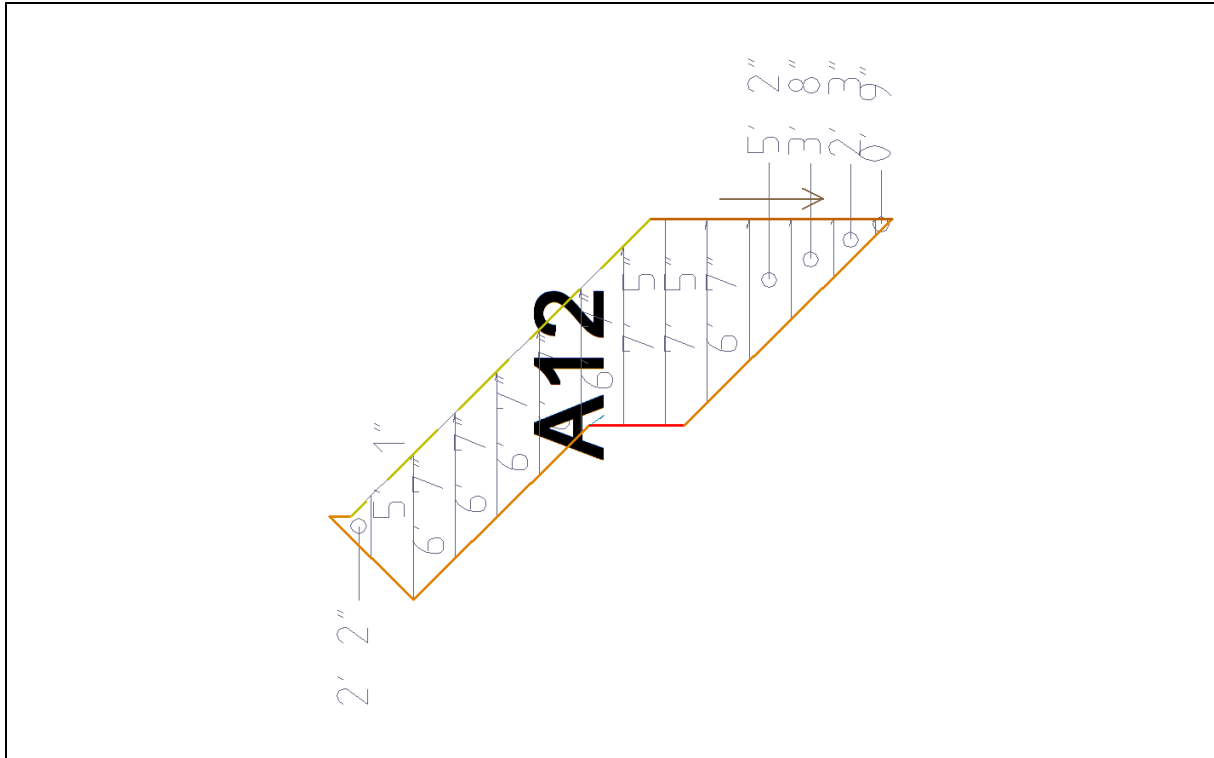

Plane A12 - 77.47 Sq. Ft.

Qty	Linear Feet	Total Lin. Feet	Qty	Linear Feet	Total Lin. Feet
2	7' 5"	14' 10"	1	4' 6"	4' 6"
6	6' 7"	39' 6"	1	3' 8"	3' 8"
1	5' 2"	5' 2"	1	3' 0"	3' 0"
1	5' 1"	5' 1"			
<b>SubTotal</b>	13	Panels			75' 9"

**Minimum Panel Length Breakdown**

- 1 / 4' 6" above made up of 1/2' 3", 1/2' 2".
- 1 / 3' above made up of 1/0' 10".

# Estimate For



**New Mart Builders Inc.**

1000 Cycle Lane  
 South Hill VA 23970  
 Email: bob.davis@newmartbuilder.com  
 Phone: 434-584-0027  
 Date: 16 December 2016



## Roof Take-Off

Job: TCD Summerwood

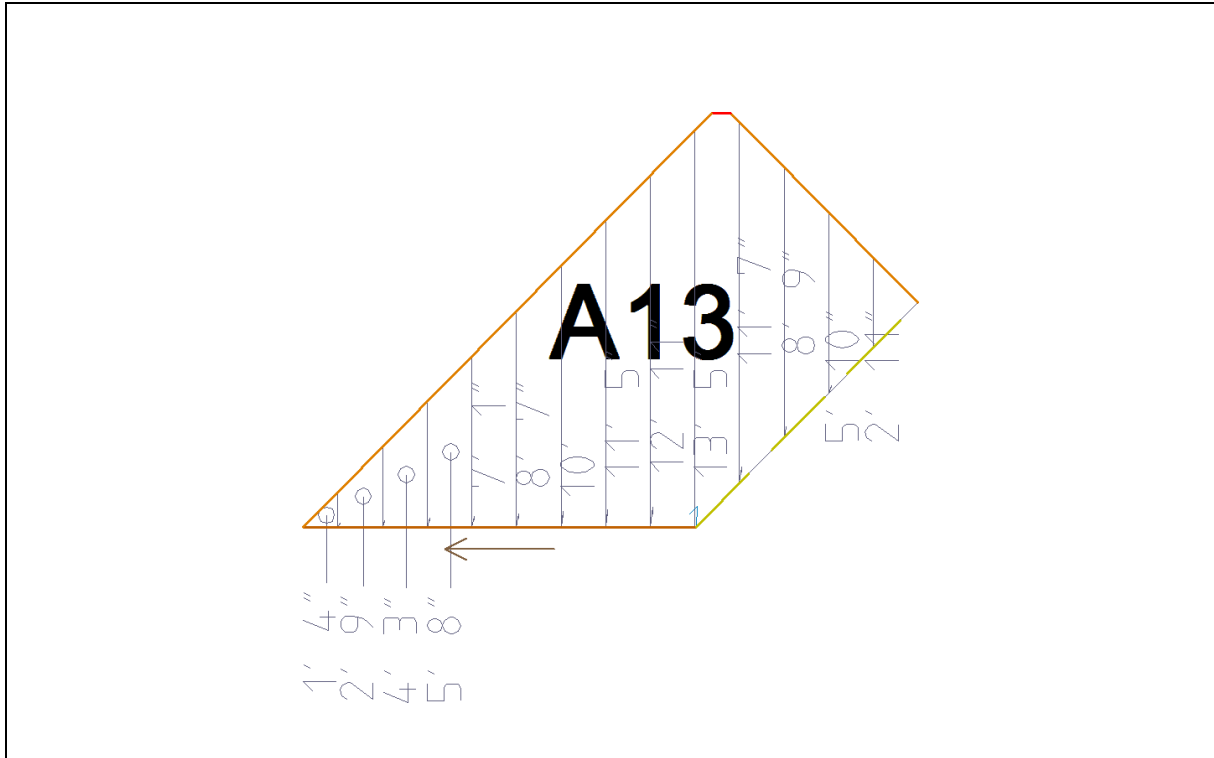

Plane A13 - 121.63 Sq. Ft.

Qty	Linear Feet	Total Lin. Feet	Qty	Linear Feet	Total Lin. Feet
1	13' 5"	13' 5"	1	8' 7"	8' 7"
1	12' 11"	12' 11"	1	7' 1"	7' 1"
1	11' 7"	11' 7"	1	5' 10"	5' 10"
1	11' 5"	11' 5"	2	5' 8"	11' 4"
1	10' 0"	10' 0"	1	4' 3"	4' 3"
1	8' 9"	8' 9"	1	3' 0"	3' 0"
<b>SubTotal</b>	13	Panels			108' 2"

**Minimum Panel Length Breakdown**

- 1 / 5' 8" above made up of 1/2' 11", 1/2' 9".
- 1 / 3' above made up of 1/1' 4".

# Estimate For



**New Mart Builders Inc.**

1000 Cycle Lane  
 South Hill VA 23970  
 Email: bob.davis@newmartbuilder.com  
 Phone: 434-584-0027  
**Date: 16 December 2016**



## Roof Take-Off

**Job: TCD Summerwood**

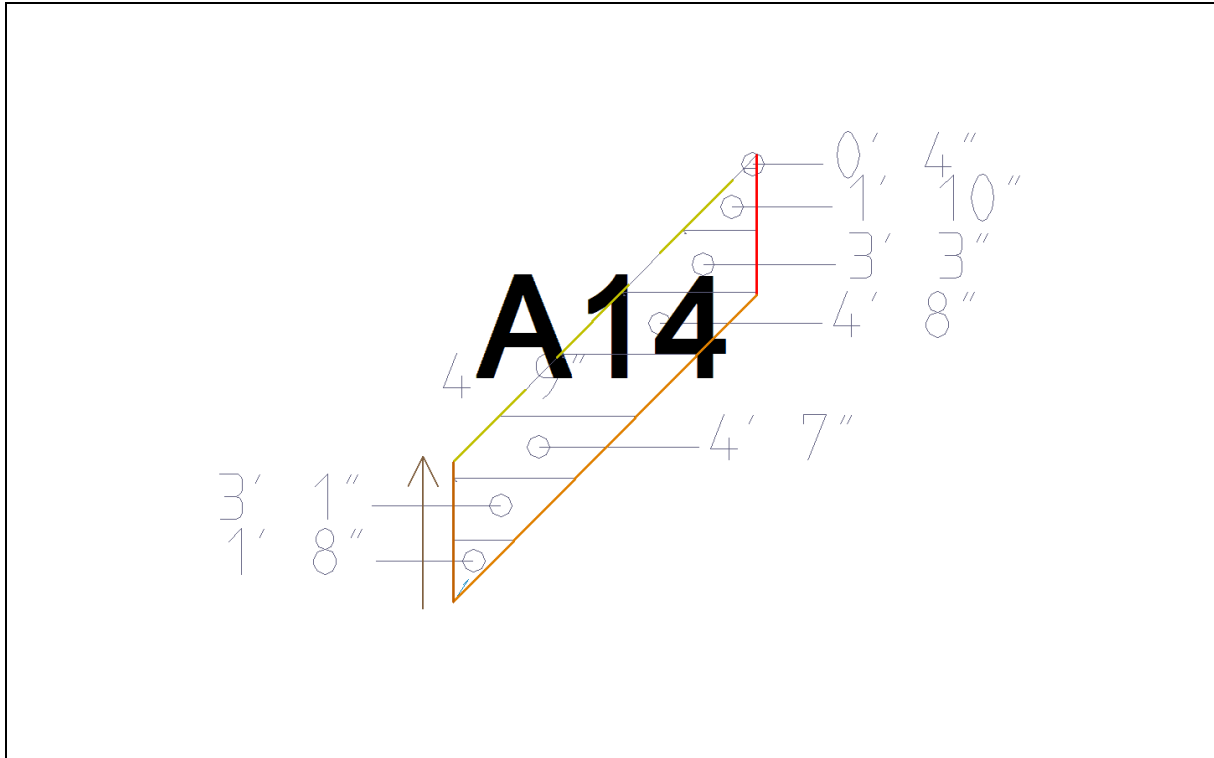

Plane A14 - 21.53 Sq. Ft.

Qty	Linear Feet	Total Lin. Feet	Qty	Linear Feet	Total Lin. Feet
1	4' 9"	4' 9"	1	3' 3"	3' 3"
1	4' 8"	4' 8"	1	3' 1"	3' 1"
1	4' 7"	4' 7"	1	3' 0"	3' 0"
1	3' 6"	3' 6"			
<b>SubTotal</b>	7	Panels			26' 10"

**Minimum Panel Length Breakdown**

- 1 / 3' 6" above made up of 1/1' 10", 1/1' 8".
- 1 / 3' above made up of 1/0' 4".



# Estimate For



**New Mart Builders Inc.**

1000 Cycle Lane  
 South Hill VA 23970  
 Email: bob.davis@newmartbuilder.com  
 Phone: 434-584-0027  
**Date: 16 December 2016**



## Roof Take-Off

**Job: TCD Summerwood**

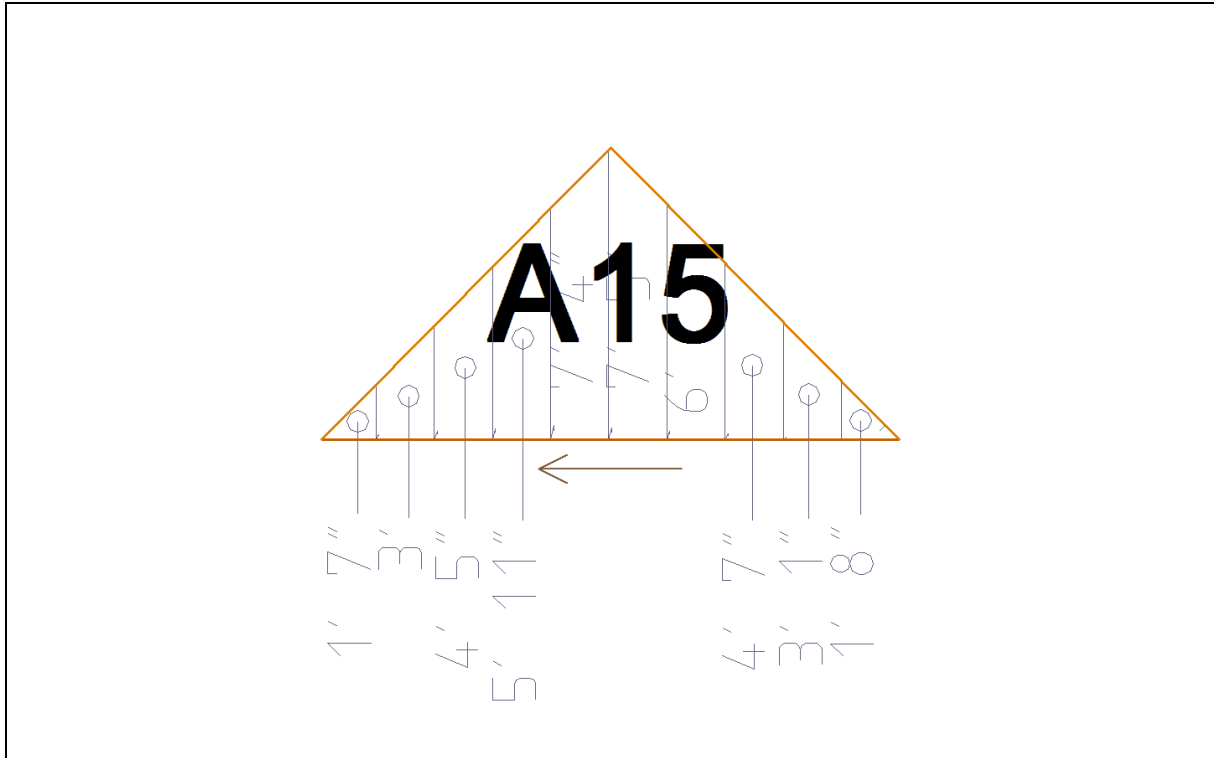

Plane A15 - 47.55 Sq. Ft.

Qty	Linear Feet	Total Lin. Feet	Qty	Linear Feet	Total Lin. Feet
1	7' 5"	7' 5"	1	4' 5"	4' 5"
1	7' 4"	7' 4"	1	3' 3"	3' 3"
1	6' 0"	6' 0"	1	3' 1"	3' 1"
1	5' 11"	5' 11"	1	3' 0"	3' 0"
1	4' 7"	4' 7"			
<b>SubTotal</b>	9	Panels			45' 0"

**Minimum Panel Length Breakdown**

1 / 3' above made up of 1/3'.  
 1 / 3' 3" above made up of 1/1' 8", 1/1' 7".

# Estimate For



**New Mart Builders Inc.**

1000 Cycle Lane  
 South Hill VA 23970  
 Email: bob.davis@newmartbuilder.com  
 Phone: 434-584-0027  
 Date: 16 December 2016



## Roof Take-Off

Job: TCD Summerwood

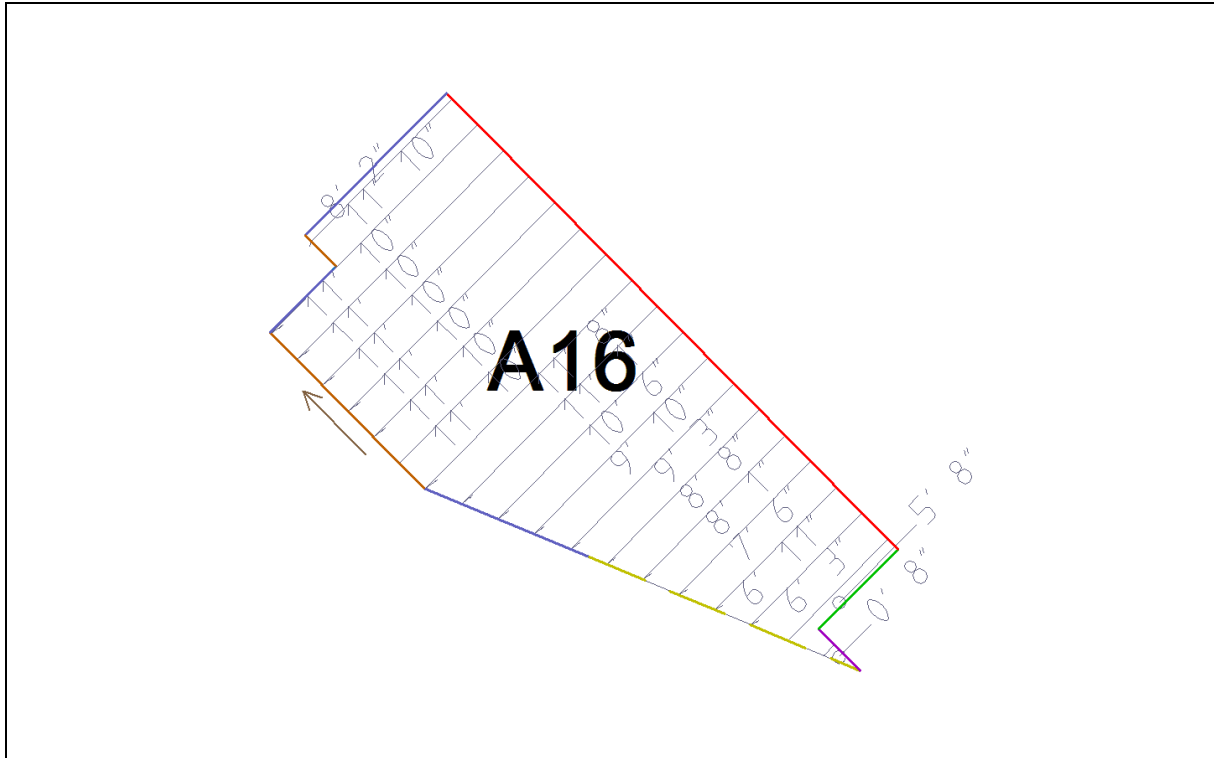

Plane A16 - 225.51 Sq. Ft.

Qty	Linear Feet	Total Lin. Feet	Qty	Linear Feet	Total Lin. Feet
7	11' 10"	82' 10"	1	8' 2"	8' 2"
1	11' 8"	11' 8"	1	8' 1"	8' 1"
1	11' 1"	11' 1"	1	7' 6"	7' 6"
1	10' 6"	10' 6"	1	6' 11"	6' 11"
1	9' 10"	9' 10"	1	6' 3"	6' 3"
1	9' 3"	9' 3"	1	5' 8"	5' 8"
1	8' 8"	8' 8"	1	3' 0"	3' 0"
<b>SubTotal</b>	20	Panels			189' 5"

**Minimum Panel Length Breakdown**

1 / 3' above made up of 1/0' 8".

# Estimate For



**New Mart Builders Inc.**

1000 Cycle Lane  
 South Hill VA 23970  
 Email: bob.davis@newmartbuilder.com  
 Phone: 434-584-0027  
 Date: 16 December 2016



## Roof Take-Off

Job: TCD Summerwood

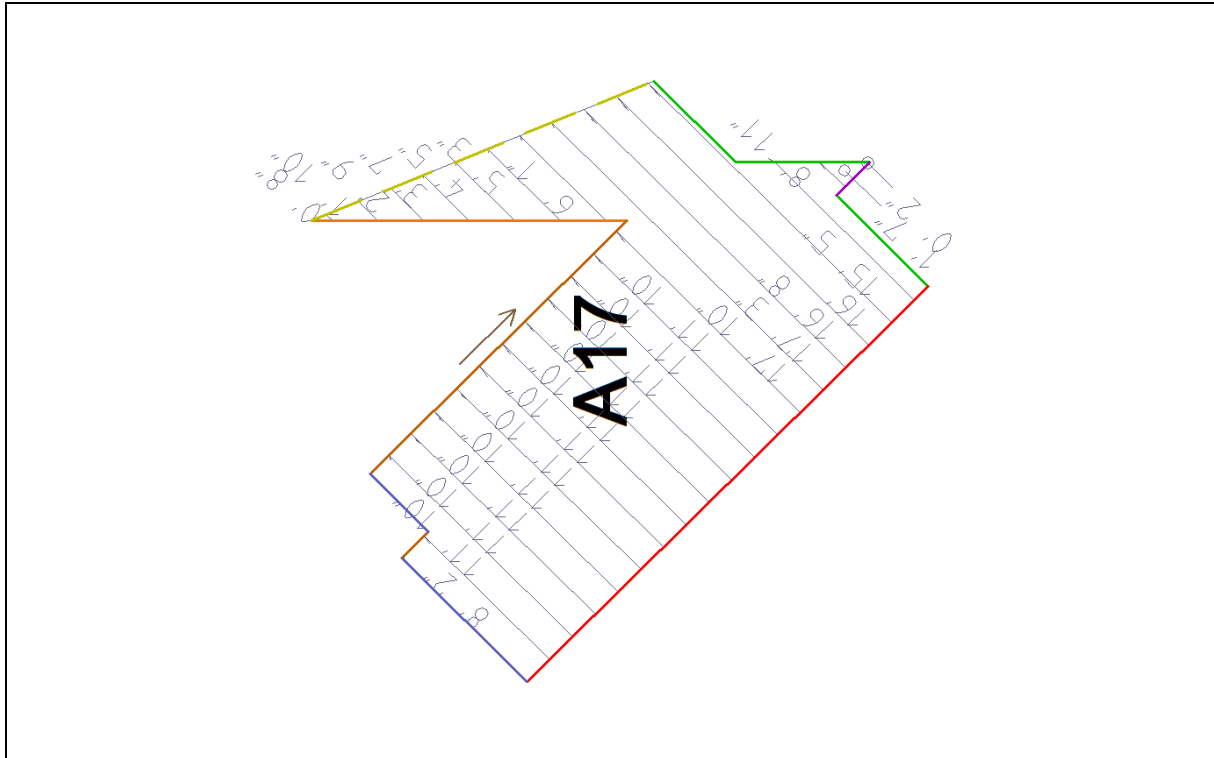

Plane A17 - 315.38 Sq. Ft.

Qty	Linear Feet	Total Lin. Feet	Qty	Linear Feet	Total Lin. Feet
1	17' 10"	17' 10"	1	8' 2"	8' 2"
1	17' 3"	17' 3"	1	6' 1"	6' 1"
1	16' 8"	16' 8"	1	5' 3"	5' 3"
1	16' 0"	16' 0"	1	4' 8"	4' 8"
1	15' 5"	15' 5"	1	4' 5"	4' 5"
11	11' 10"	130' 2"	1	3' 7"	3' 7"
1	8' 11"	8' 11"	1	3' 0"	3' 0"
<b>SubTotal</b>	24	Panels			257' 5"

### Minimum Panel Length Breakdown

1 / 4' 8" above made up of 1/2' 9", 1/1' 11".  
 1 / 3' above made up of 1/1' 7", 1/0' 9", 1/0' 2".

# Estimate For



**New Mart Builders Inc.**

1000 Cycle Lane  
 South Hill VA 23970  
 Email: bob.davis@newmartbuilder.com  
 Phone: 434-584-0027  
**Date: 16 December 2016**



## Roof Take-Off

**Job: TCD Summerwood**

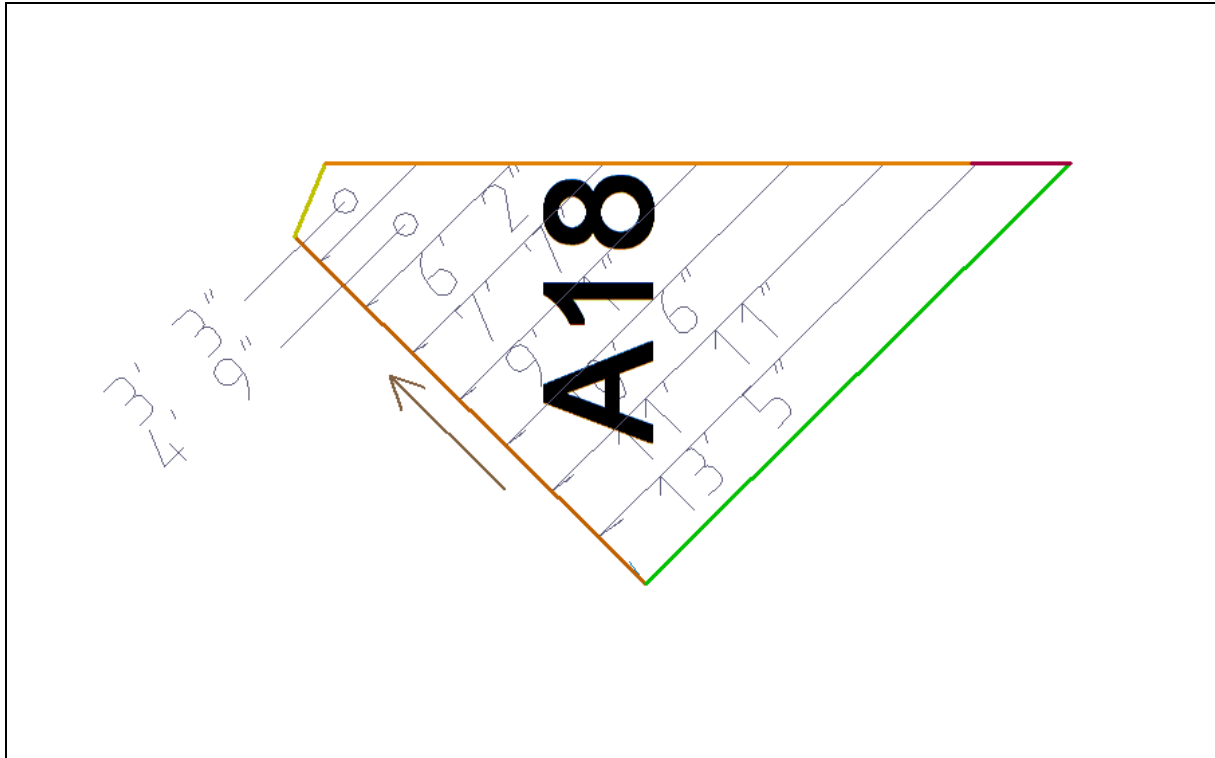

Plane A18 - 78.34 Sq. Ft.

Qty	Linear Feet	Total Lin. Feet	Qty	Linear Feet	Total Lin. Feet
1	13' 5"	13' 5"	1	7' 7"	7' 7"
1	11' 11"	11' 11"	1	6' 2"	6' 2"
1	10' 6"	10' 6"	1	4' 9"	4' 9"
1	9' 1"	9' 1"	1	3' 3"	3' 3"
<b>SubTotal</b>	8	Panels			66' 8"

# Estimate For



**New Mart Builders Inc.**

1000 Cycle Lane  
 South Hill VA 23970  
 Email: bob.davis@newmartbuilder.com  
 Phone: 434-584-0027  
 Date: 16 December 2016



# Roof Take-Off

**Job: TCD Summerwood**

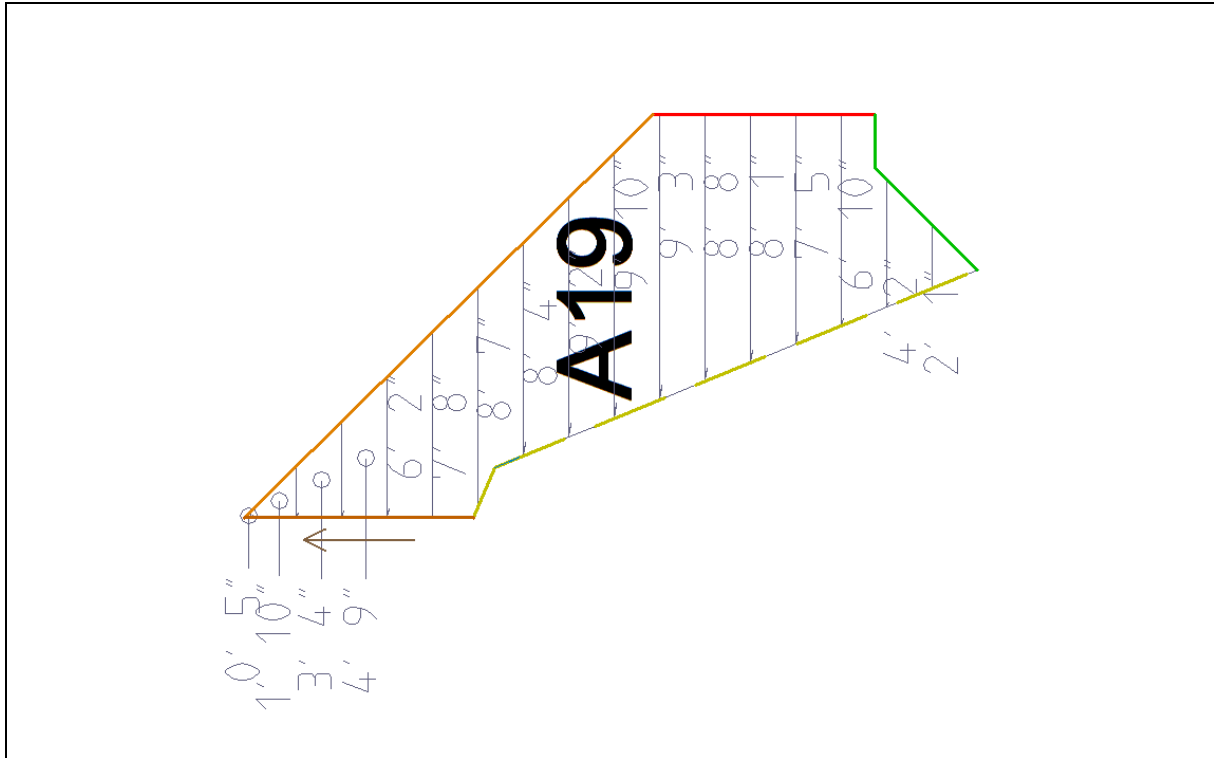

Plane A19 - 123.03 Sq. Ft.

Qty	Linear Feet	Total Lin. Feet	Qty	Linear Feet	Total Lin. Feet
1	9' 10"	9' 10"	1	7' 5"	7' 5"
1	9' 3"	9' 3"	1	6' 10"	6' 10"
1	9' 2"	9' 2"	1	6' 2"	6' 2"
1	8' 8"	8' 8"	1	4' 9"	4' 9"
1	8' 7"	8' 7"	1	4' 2"	4' 2"
1	8' 4"	8' 4"	1	3' 11"	3' 11"
1	8' 1"	8' 1"	1	3' 4"	3' 4"
1	7' 8"	7' 8"	1	3' 0"	3' 0"
<b>SubTotal</b>	16	Panels			109' 2"

**Minimum Panel Length Breakdown**

- 1 / 3' 11" above made up of 1/2' 1", 1/1' 10".
- 1 / 3' above made up of 1/0' 5".

# Estimate For



**New Mart Builders Inc.**

1000 Cycle Lane  
 South Hill VA 23970  
 Email: bob.davis@newmartbuilder.com  
 Phone: 434-584-0027  
**Date: 16 December 2016**



## Roof Take-Off

**Job: TCD Summerwood**

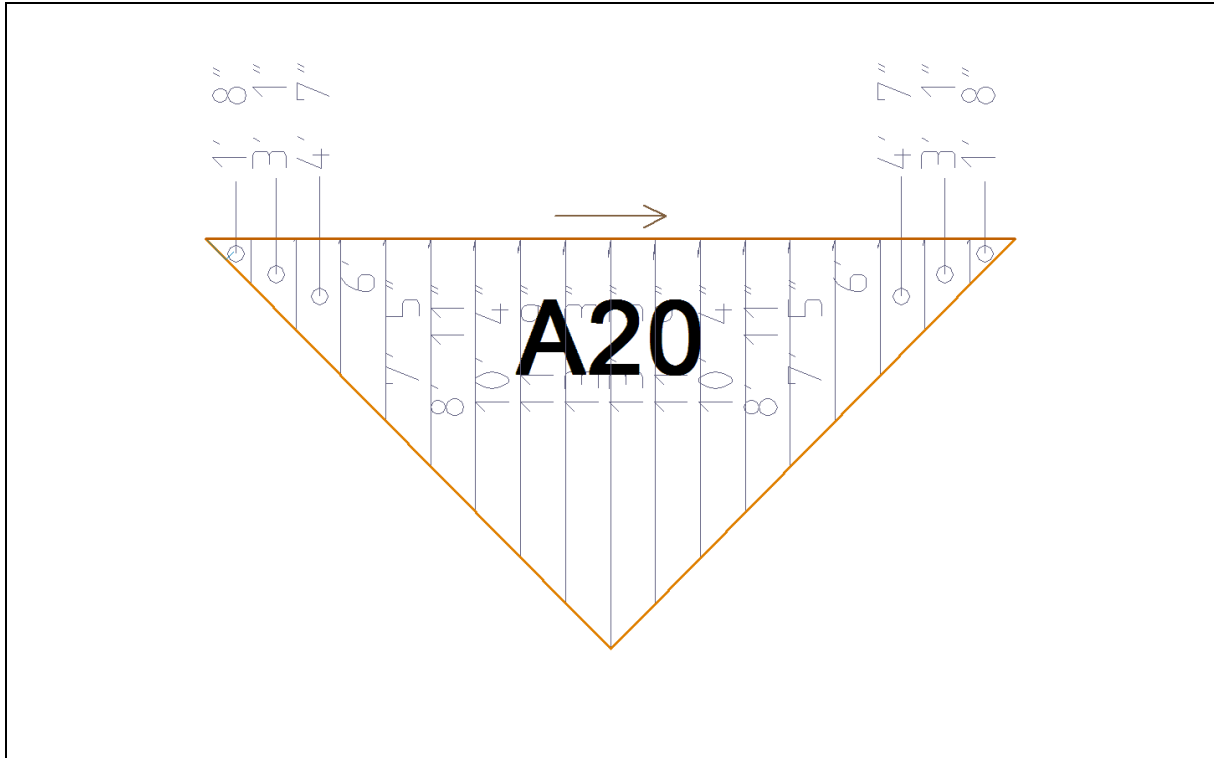

Plane A20 - 156.00 Sq. Ft.

Qty	Linear Feet	Total Lin. Feet	Qty	Linear Feet	Total Lin. Feet
2	13' 3"	26' 6"	2	6' 0"	12' 0"
2	11' 9"	23' 6"	2	4' 7"	9' 2"
2	10' 4"	20' 8"	1	3' 4"	3' 4"
2	8' 11"	17' 10"	2	3' 1"	6' 2"
2	7' 5"	14' 10"			
<b>SubTotal</b>	17	Panels			134' 0"

**Minimum Panel Length Breakdown**

1 / 3' 4" above made up of 2/1' 8".

# Estimate For



**New Mart Builders Inc.**

1000 Cycle Lane  
 South Hill VA 23970  
 Email: bob.davis@newmartbuilder.com  
 Phone: 434-584-0027  
**Date: 16 December 2016**



## Roof Take-Off

**Job: TCD Summerwood**

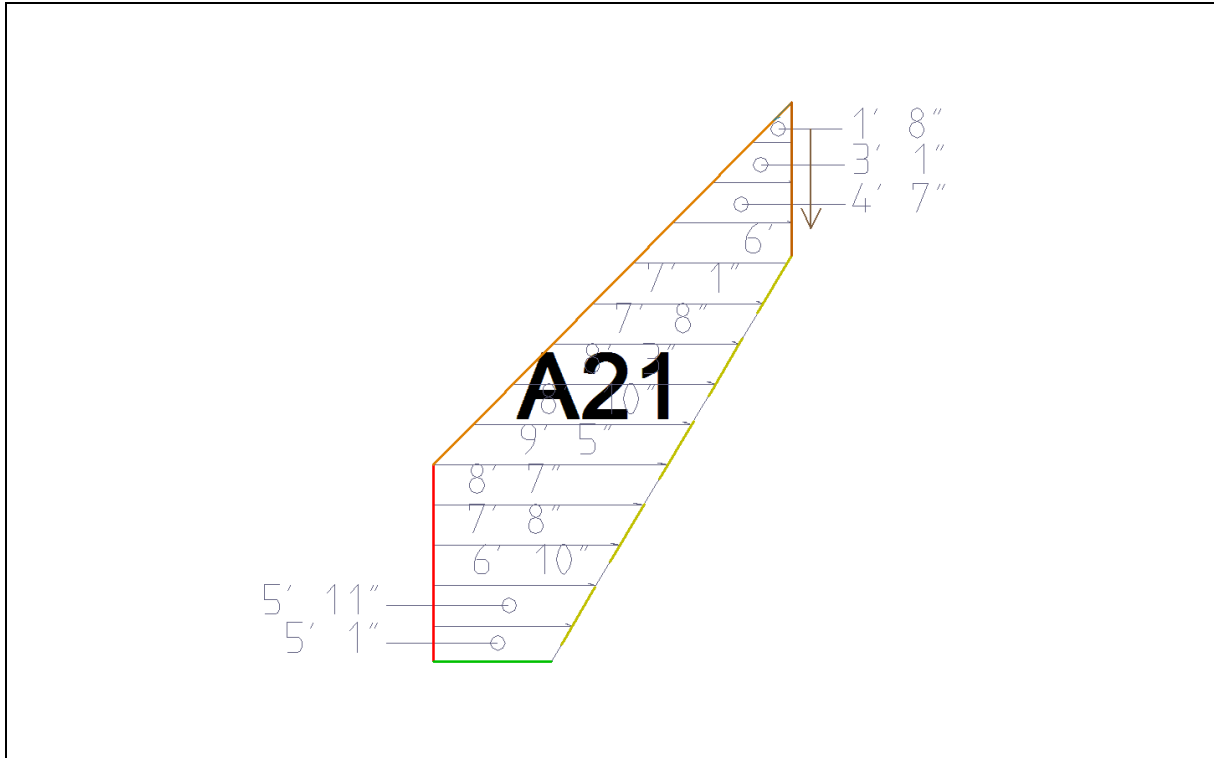

Plane A21 - 104.04 Sq. Ft.

Qty	Linear Feet	Total Lin. Feet	Qty	Linear Feet	Total Lin. Feet
1	9' 5"	9' 5"	1	6' 0"	6' 0"
1	8' 10"	8' 10"	1	5' 11"	5' 11"
1	8' 7"	8' 7"	1	5' 1"	5' 1"
1	8' 3"	8' 3"	1	4' 7"	4' 7"
2	7' 8"	15' 4"	1	3' 1"	3' 1"
1	7' 1"	7' 1"	1	3' 0"	3' 0"
1	6' 10"	6' 10"			
<b>SubTotal</b>	14	Panels			92' 0"

**Minimum Panel Length Breakdown**

1 / 3' above made up of 1/1' 8".

# Estimate For



**New Mart Builders Inc.**

1000 Cycle Lane  
 South Hill VA 23970  
 Email: bob.davis@newmartbuilder.com  
 Phone: 434-584-0027  
**Date: 16 December 2016**



## Roof Take-Off

**Job: TCD Summerwood**

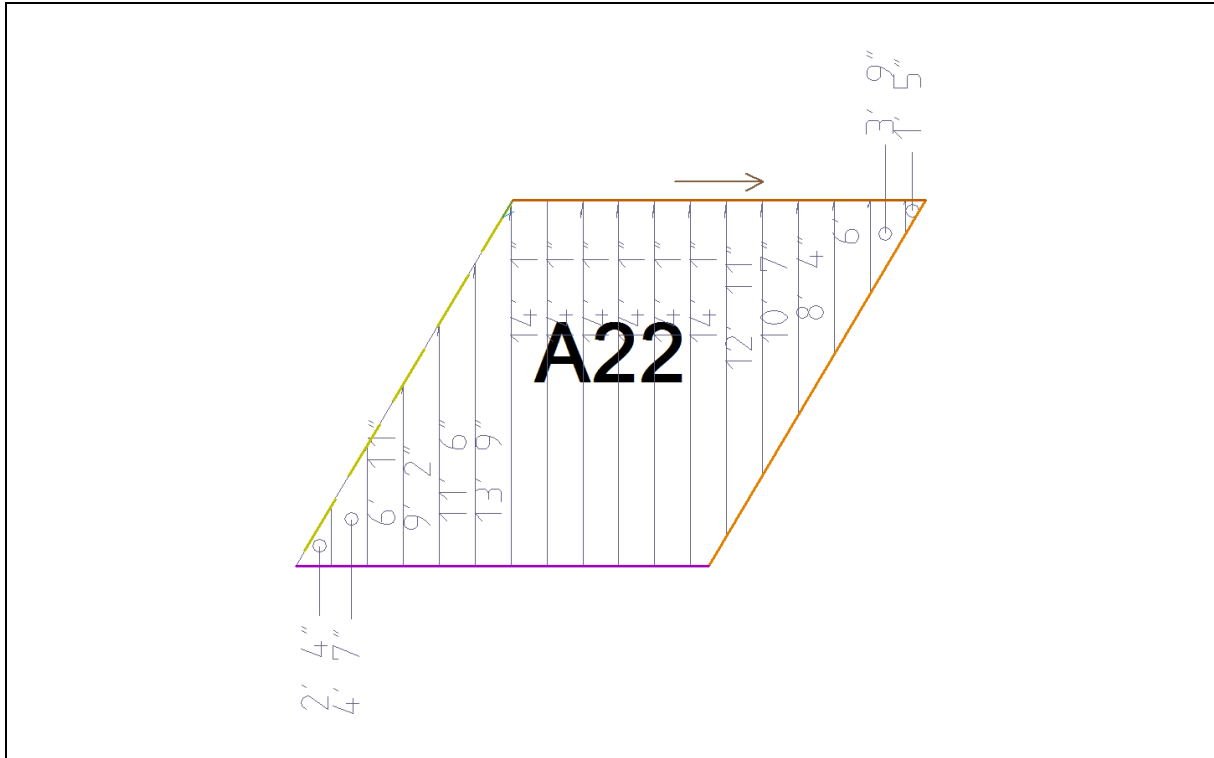

Plane A22 - 212.20 Sq. Ft.

Qty	Linear Feet	Total Lin. Feet	Qty	Linear Feet	Total Lin. Feet
6	14' 1"	84' 6"	1	8' 4"	8' 4"
1	13' 9"	13' 9"	1	6' 11"	6' 11"
1	12' 11"	12' 11"	1	6' 0"	6' 0"
1	11' 6"	11' 6"	1	4' 7"	4' 7"
1	10' 7"	10' 7"	2	3' 9"	7' 6"
1	9' 2"	9' 2"			
<b>SubTotal</b>	17	Panels			175' 9"

**Minimum Panel Length Breakdown**

1 / 3' 9" above made up of 1/2' 4", 1/1' 5".



# Estimate For



**New Mart Builders Inc.**  
 1000 Cycle Lane  
 South Hill VA 23970  
 Email: bob.davis@newmartbuilder.com  
 Phone: 434-584-0027  
 Date: 16 December 2016



## Roof Take-Off

**Job: TCD Summerwood**

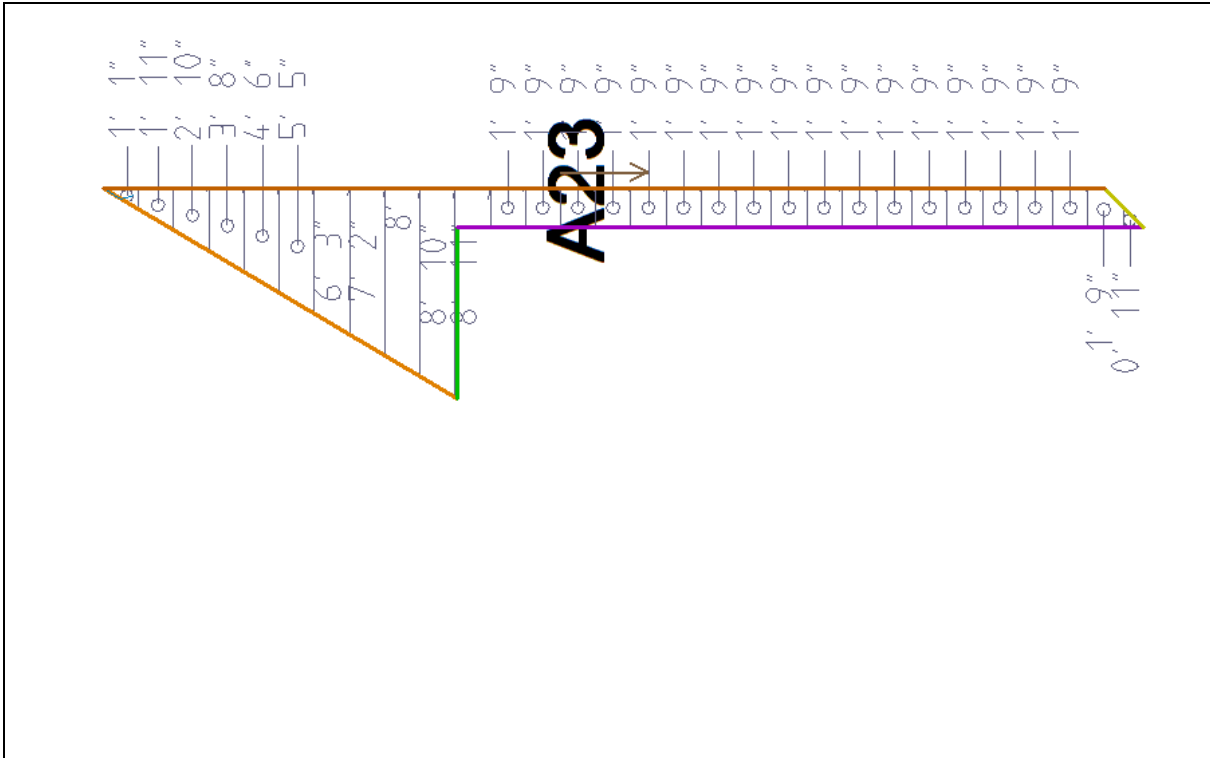

Plane A23 - 98.24 Sq. Ft.

Qty	Linear Feet	Total Lin. Feet	Qty	Linear Feet	Total Lin. Feet
1	8' 11"	8' 11"	1	4' 9"	4' 9"
1	8' 10"	8' 10"	1	4' 6"	4' 6"
1	8' 0"	8' 0"	1	3' 8"	3' 8"
1	7' 2"	7' 2"	9	3' 6"	31' 6"
1	6' 3"	6' 3"	1	3' 0"	3' 0"
1	5' 5"	5' 5"			
<b>SubTotal</b>	19	Panels			92' 0"

**Minimum Panel Length Breakdown**

- 1 / 4' 9" above made up of 1/2' 10", 1/1' 11".
- 1 / 3' 6" above made up of 2/1' 9".
- 1 / 3' 6" above made up of 2/1' 9".
- 1 / 3' 6" above made up of 2/1' 9".
- 1 / 3' 6" above made up of 2/1' 9".
- 1 / 3' 6" above made up of 2/1' 9".
- 1 / 3' 6" above made up of 2/1' 9".
- 1 / 3' 6" above made up of 2/1' 9".
- 1 / 3' 6" above made up of 2/1' 9".
- 1 / 3' 6" above made up of 2/1' 9".
- 1 / 3' 6" above made up of 2/1' 9".
- 1 / 3' 6" above made up of 2/1' 9".
- 1 / 3' 6" above made up of 2/1' 9".
- 1 / 3' 6" above made up of 2/1' 9".
- 1 / 3' 6" above made up of 2/1' 9".
- 1 / 3' above made up of 1/1' 1", 1/0' 11".

# Estimate For



**New Mart Builders Inc.**

1000 Cycle Lane  
 South Hill VA 23970  
 Email: bob.davis@newmartbuilder.com  
 Phone: 434-584-0027  
 Date: 16 December 2016



## Roof Take-Off

Job: TCD Summerwood

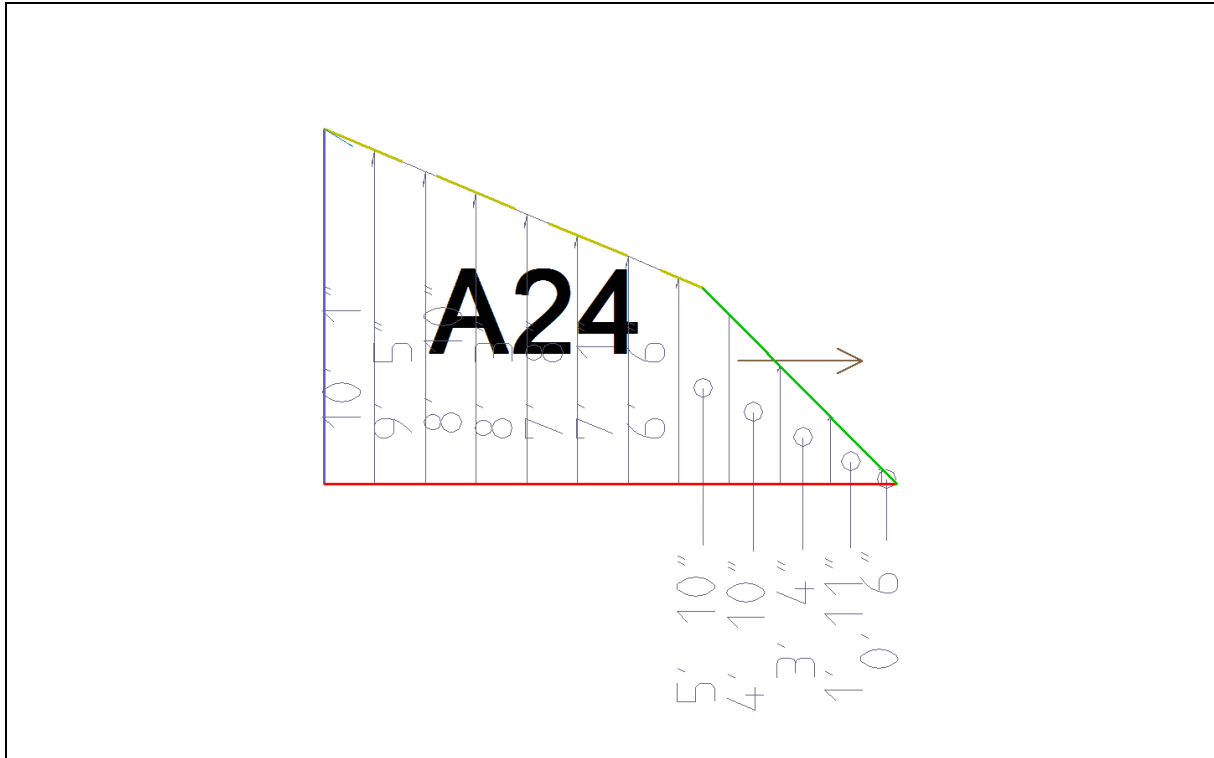

Plane A24 - 91.59 Sq. Ft.

Qty	Linear Feet	Total Lin. Feet	Qty	Linear Feet	Total Lin. Feet
1	10' 1"	10' 1"	1	6' 6"	6' 6"
1	9' 5"	9' 5"	1	5' 10"	5' 10"
1	8' 10"	8' 10"	1	4' 10"	4' 10"
1	8' 3"	8' 3"	1	3' 4"	3' 4"
1	7' 8"	7' 8"	1	3' 0"	3' 0"
1	7' 1"	7' 1"			
<b>SubTotal</b>	11	Panels			74' 10"

**Minimum Panel Length Breakdown**

1 / 3' above made up of 1/1' 11", 1/0' 6".

# Estimate For



**New Mart Builders Inc.**

1000 Cycle Lane  
 South Hill VA 23970  
 Email: bob.davis@newmartbuilder.com  
 Phone: 434-584-0027  
 Date: 16 December 2016



## Roof Take-Off

Job: TCD Summerwood

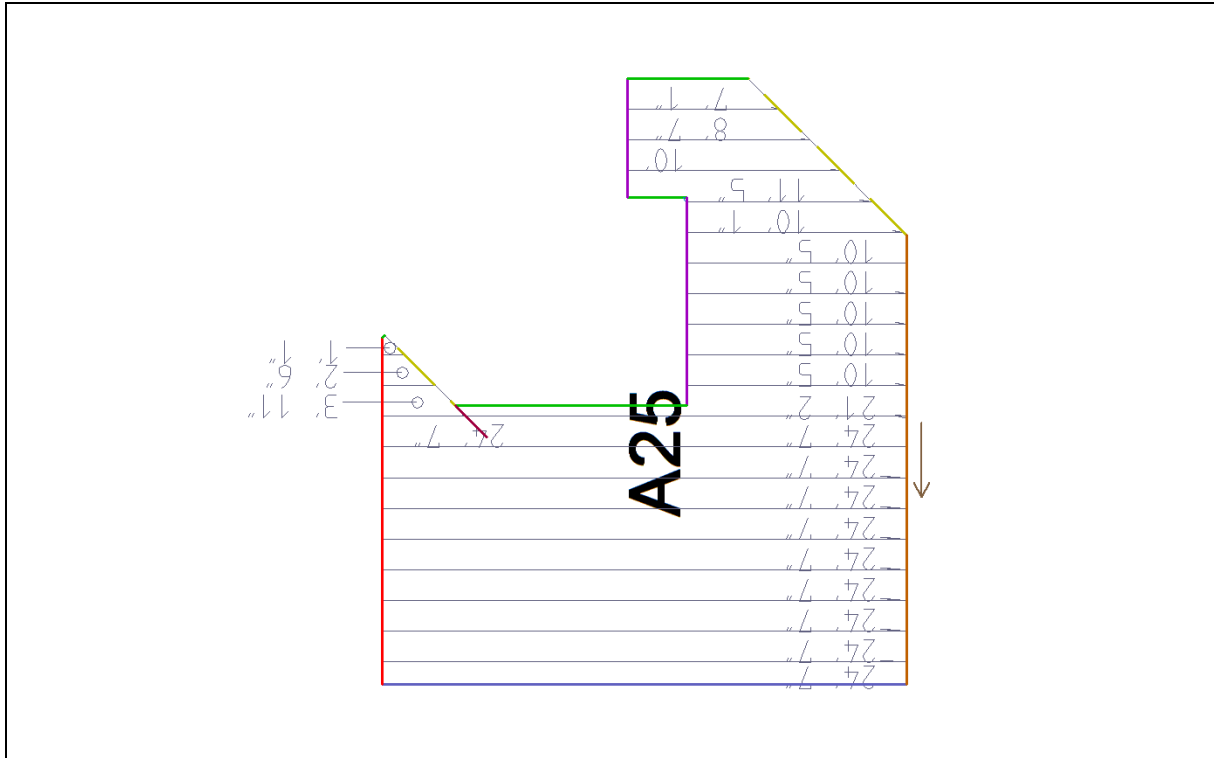

Plane A25 - 434.96 Sq. Ft.

Qty	Linear Feet	Total Lin. Feet	Qty	Linear Feet	Total Lin. Feet
10	24' 7"	245' 10"	1	10' 0"	10' 0"
1	21' 2"	21' 2"	1	8' 7"	8' 7"
1	11' 5"	11' 5"	1	7' 1"	7' 1"
5	10' 5"	52' 1"	1	3' 11"	3' 11"
1	10' 1"	10' 1"	1	3' 7"	3' 7"
<b>SubTotal</b>	23	Panels			373' 9"

**Minimum Panel Length Breakdown**

1 / 3' 7" above made up of 1/2' 6", 1/1' 1".

# Estimate For



**New Mart Builders Inc.**

1000 Cycle Lane  
 South Hill VA 23970  
 Email: bob.davis@newmartbuilder.com  
 Phone: 434-584-0027  
**Date: 16 December 2016**



## Roof Take-Off

**Job: TCD Summerwood**

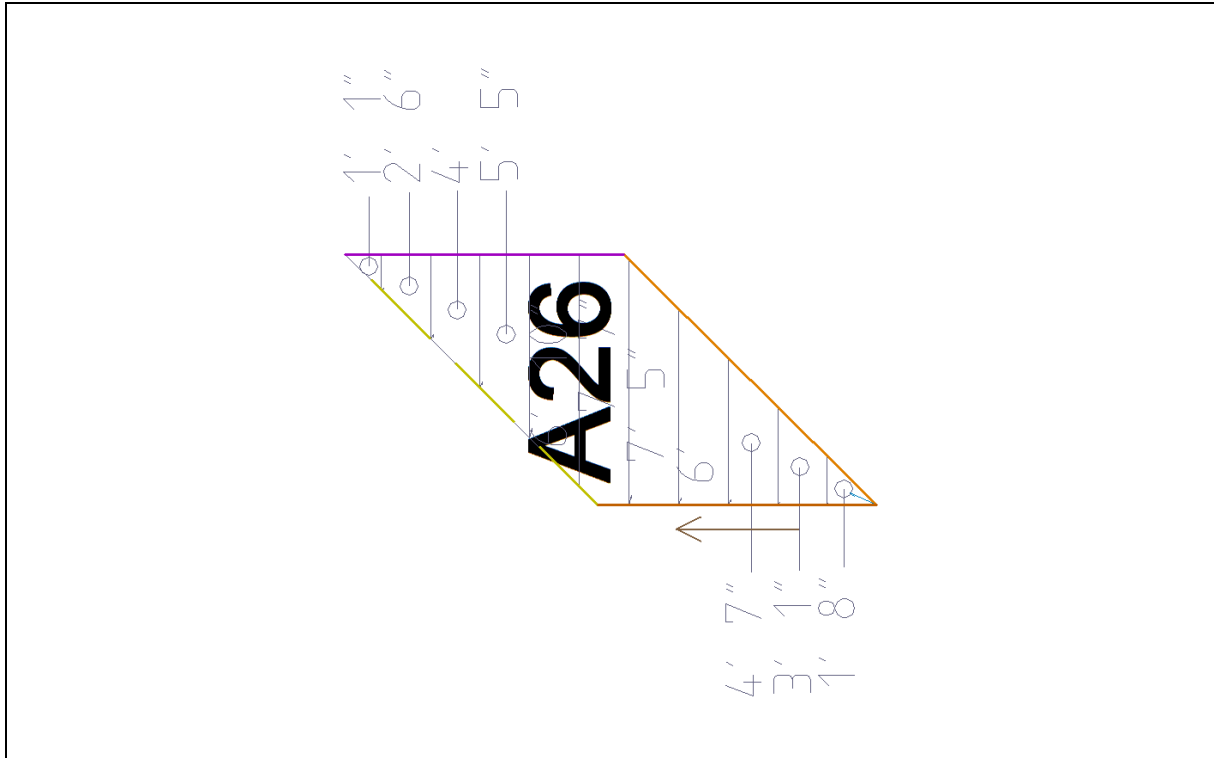

Plane A26 - 55.27 Sq. Ft.

Qty	Linear Feet	Total Lin. Feet	Qty	Linear Feet	Total Lin. Feet
1	7' 7"	7' 7"	1	4' 7"	4' 7"
1	7' 5"	7' 5"	1	4' 2"	4' 2"
1	6' 10"	6' 10"	1	4' 0"	4' 0"
1	6' 0"	6' 0"	1	3' 1"	3' 1"
1	5' 5"	5' 5"	1	3' 0"	3' 0"
<b>SubTotal</b>	10	Panels			52' 1"

**Minimum Panel Length Breakdown**

1 / 4' 2" above made up of 1/2' 6", 1/1' 8".

1 / 3' above made up of 1/1' 1".

# Estimate For



**New Mart Builders Inc.**

1000 Cycle Lane  
 South Hill VA 23970  
 Email: bob.davis@newmartbuilder.com  
 Phone: 434-584-0027  
 Date: 16 December 2016



## Roof Take-Off

Job: TCD Summerwood

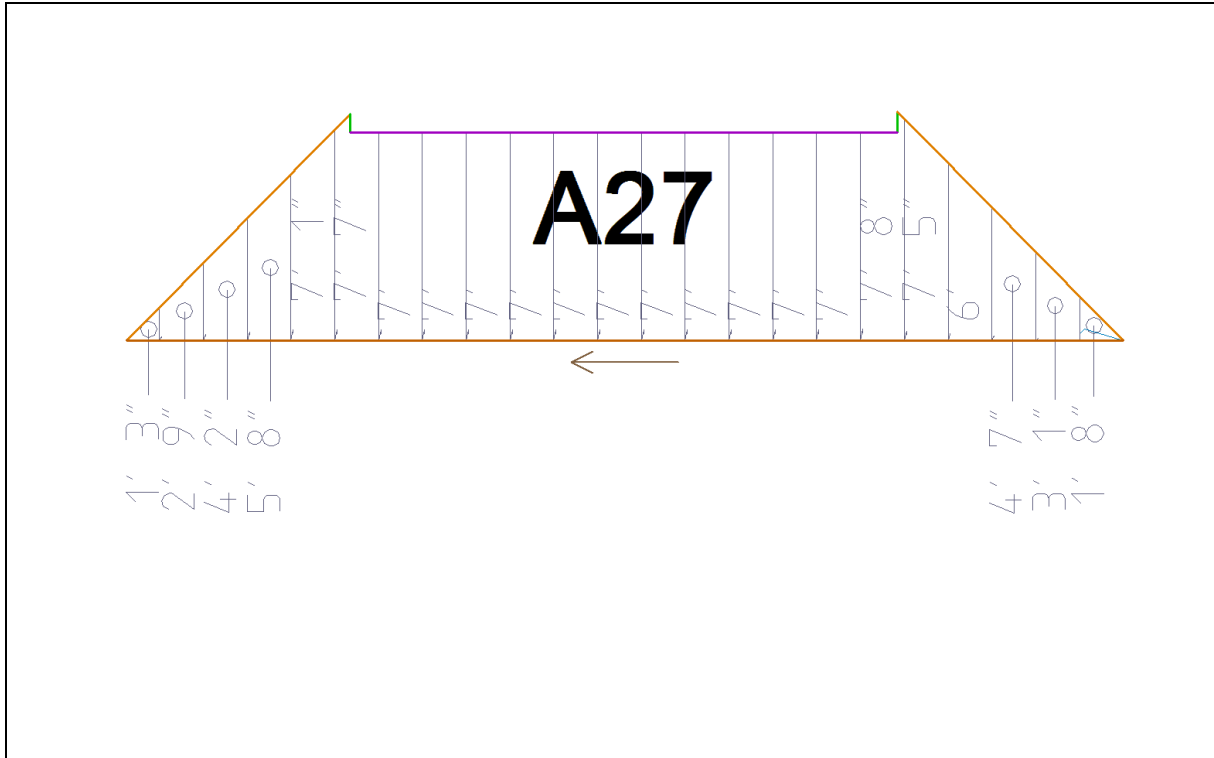

Plane A27 - 163.27 Sq. Ft.

Qty	Linear Feet	Total Lin. Feet	Qty	Linear Feet	Total Lin. Feet
1	7' 8"	7' 8"	1	5' 8"	5' 8"
1	7' 7"	7' 7"	1	4' 7"	4' 7"
1	7' 5"	7' 5"	1	4' 5"	4' 5"
1	7' 1"	7' 1"	1	4' 2"	4' 2"
11	7' 0"	77' 0"	1	3' 1"	3' 1"
1	6' 0"	6' 0"	1	3' 0"	3' 0"
<b>SubTotal</b>	22	Panels			137' 8"

**Minimum Panel Length Breakdown**

- 1 / 4' 5" above made up of 1/2' 9", 1/1' 8".
- 1 / 3' above made up of 1/1' 3".

# Estimate For



**New Mart Builders Inc.**

1000 Cycle Lane  
 South Hill VA 23970  
 Email: bob.davis@newmartbuilder.com  
 Phone: 434-584-0027  
**Date: 16 December 2016**



## Roof Take-Off

**Job: TCD Summerwood**

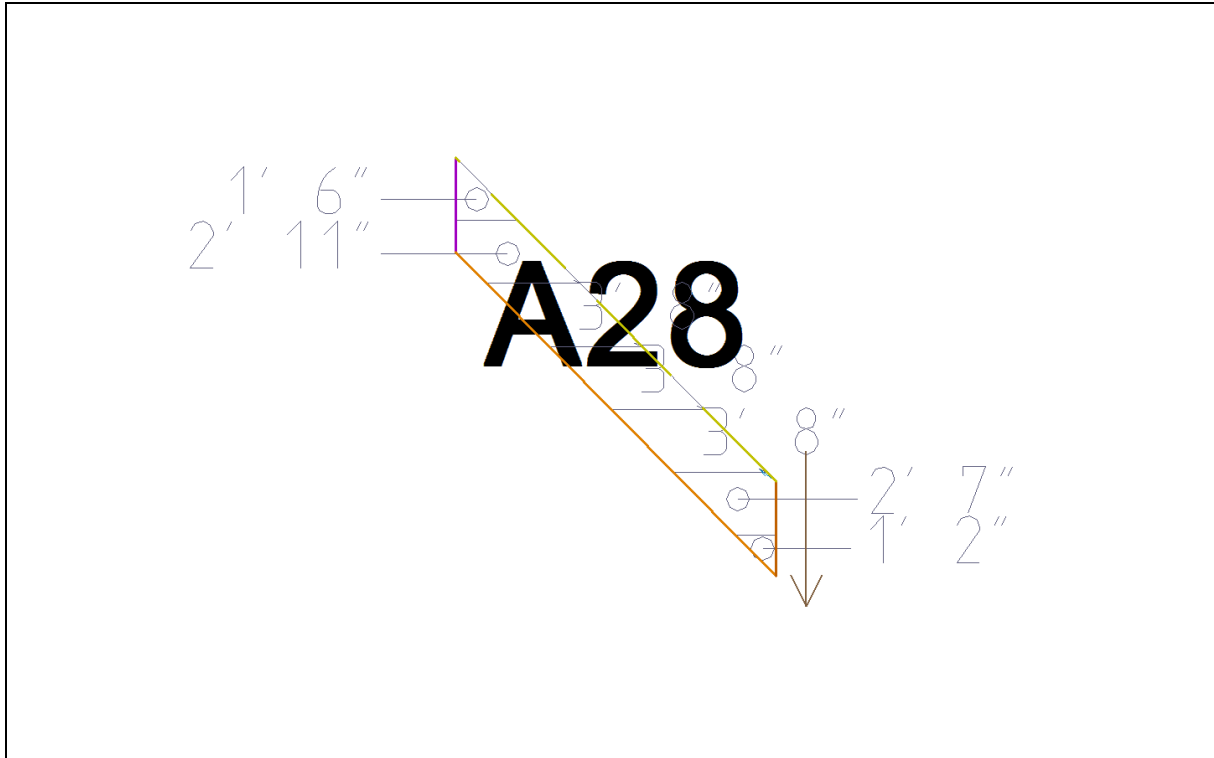

Plane A28 - 14.87 Sq. Ft.

Qty	Linear Feet	Total Lin. Feet	Qty	Linear Feet	Total Lin. Feet
1	5' 6"	5' 6"	1	3' 0"	3' 0"
3	3' 8"	11' 0"			
<b>SubTotal</b>	5	Panels			19' 6"

**Minimum Panel Length Breakdown**

- 1 / 5' 6" above made up of 1/2' 11", 1/2' 7".
- 1 / 3' above made up of 1/1' 6", 1/1' 2".

# Estimate For



**New Mart Builders Inc.**

1000 Cycle Lane  
 South Hill VA 23970  
 Email: bob.davis@newmartbuilder.com  
 Phone: 434-584-0027  
**Date: 16 December 2016**



## Roof Take-Off

**Job: TCD Summerwood**

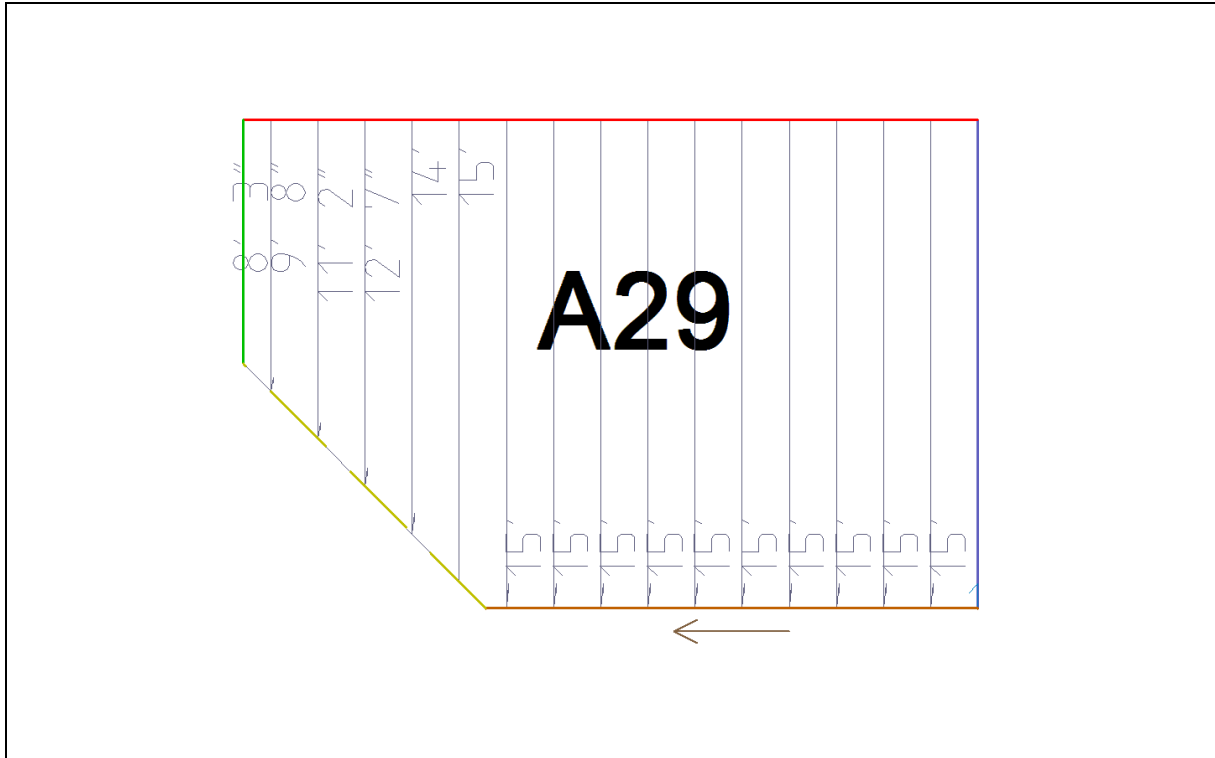

Plane A29 - 282.15 Sq. Ft.

Qty	Linear Feet	Total Lin. Feet	Qty	Linear Feet	Total Lin. Feet
11	15' 0"	165' 0"	1	11' 2"	11' 2"
1	14' 0"	14' 0"	1	9' 8"	9' 8"
1	12' 7"	12' 7"	1	8' 3"	8' 3"
<b>SubTotal</b>	16	Panels			220' 8"

# Estimate For



**New Mart Builders Inc.**

1000 Cycle Lane  
 South Hill VA 23970  
 Email: bob.davis@newmartbuilder.com  
 Phone: 434-584-0027  
**Date: 16 December 2016**



## Roof Take-Off

**Job: TCD Summerwood**

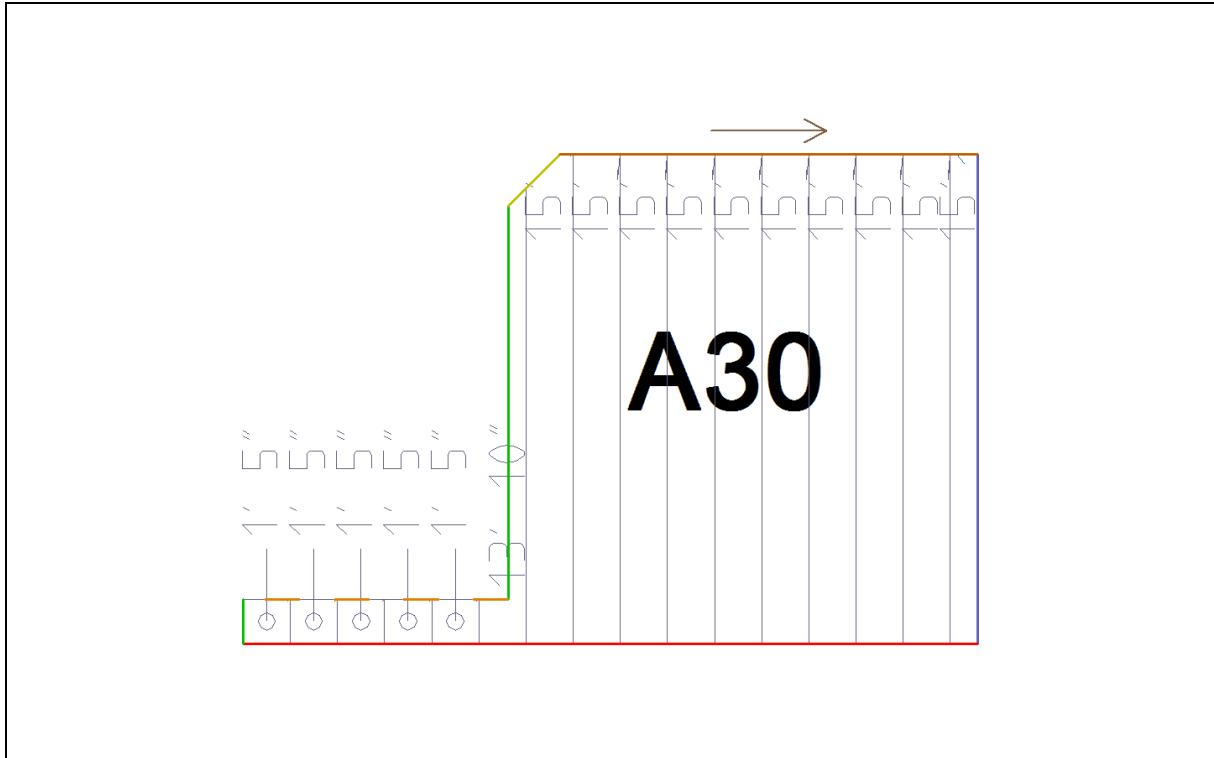

Plane A30 - 205.57 Sq. Ft.

Qty	Linear Feet	Total Lin. Feet	Qty	Linear Feet	Total Lin. Feet
10	15' 0"	150' 0"	1	4' 3"	4' 3"
1	13' 10"	13' 10"	1	3' 0"	3' 0"
<b>SubTotal</b>	13	Panels			171' 1"

**Minimum Panel Length Breakdown**

- 1 / 4' 3" above made up of 3/1' 5".
- 1 / 3' above made up of 2/1' 5".



# Estimate For



**New Mart Builders Inc.**

1000 Cycle Lane  
 South Hill VA 23970  
 Email: bob.davis@newmartbuilder.com  
 Phone: 434-584-0027  
 Date: 16 December 2016



## Roof Take-Off

Job: TCD Summerwood

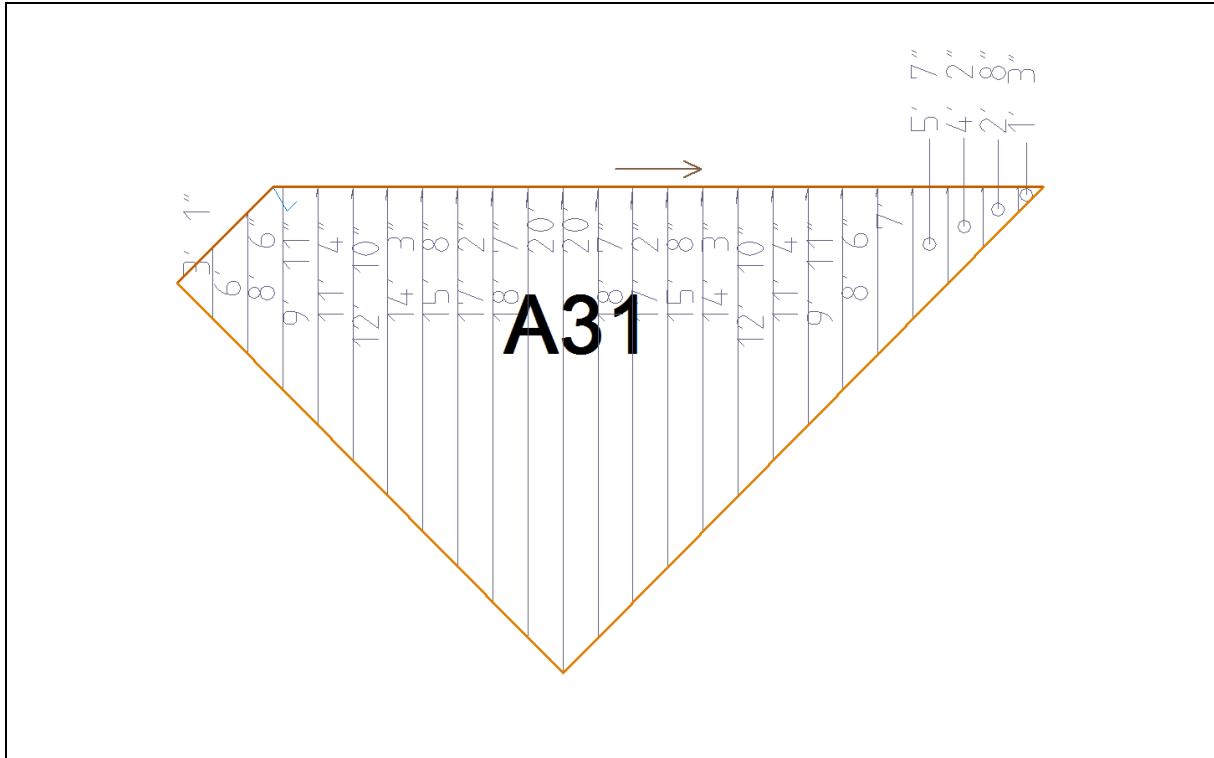

Plane A31 - 348.23 Sq. Ft.

Qty	Linear Feet	Total Lin. Feet	Qty	Linear Feet	Total Lin. Feet
2	20' 0"	40' 0"	2	8' 6"	17' 0"
2	18' 7"	37' 2"	1	7' 0"	7' 0"
2	17' 2"	34' 4"	1	6' 0"	6' 0"
2	15' 8"	31' 4"	1	5' 7"	5' 7"
2	14' 3"	28' 6"	1	4' 2"	4' 2"
2	12' 10"	25' 8"	1	3' 11"	3' 11"
2	11' 4"	22' 8"	1	3' 1"	3' 1"
2	9' 11"	19' 10"			
<b>SubTotal</b>	24	Panels			286' 3"

**Minimum Panel Length Breakdown**

1 / 3' 11" above made up of 1/2' 8", 1/1' 3".

# Estimate For



**New Mart Builders Inc.**

1000 Cycle Lane  
 South Hill VA 23970  
 Email: bob.davis@newmartbuilder.com  
 Phone: 434-584-0027  
 Date: 16 December 2016



## Roof Take-Off

Job: TCD Summerwood

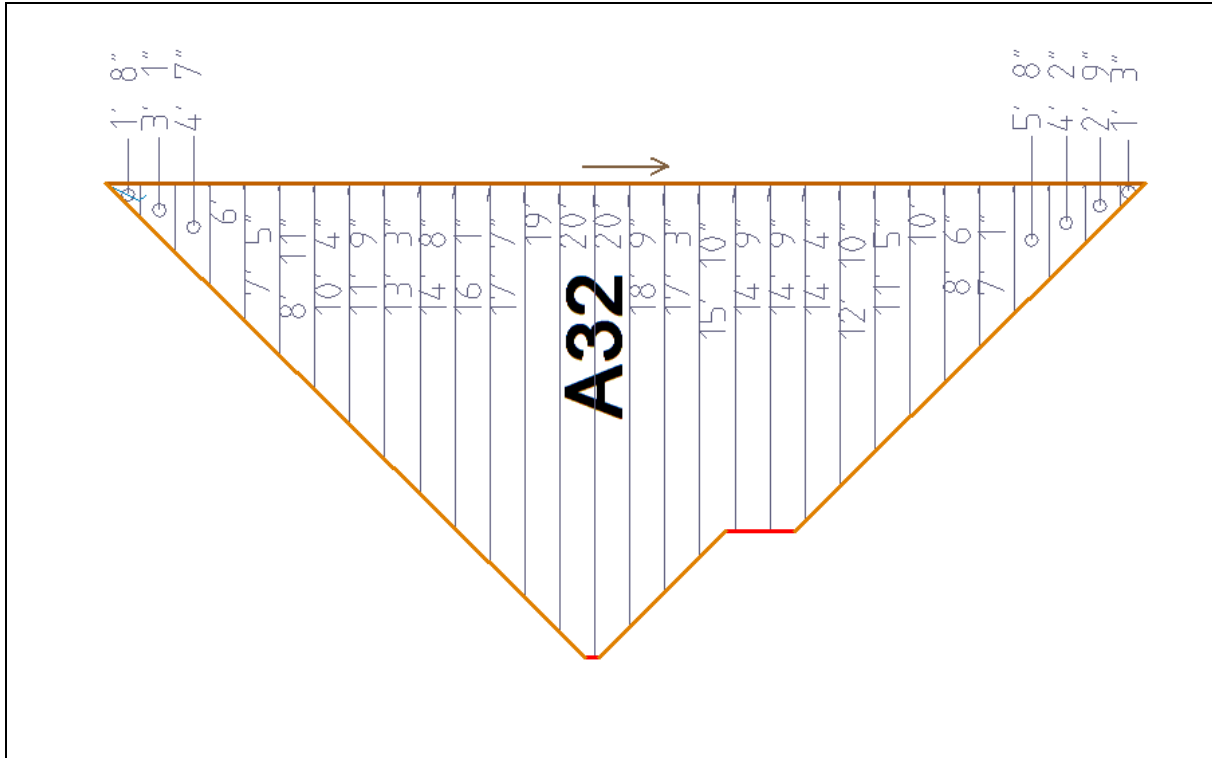

Plane A32 - 409.92 Sq. Ft.

Qty	Linear Feet	Total Lin. Feet	Qty	Linear Feet	Total Lin. Feet
2	20' 0"	40' 0"	1	10' 4"	10' 4"
1	19' 0"	19' 0"	1	10' 0"	10' 0"
1	18' 9"	18' 9"	1	8' 11"	8' 11"
1	17' 7"	17' 7"	1	8' 6"	8' 6"
1	17' 3"	17' 3"	1	7' 5"	7' 5"
1	16' 1"	16' 1"	1	7' 1"	7' 1"
1	15' 10"	15' 10"	1	6' 0"	6' 0"
2	14' 9"	29' 6"	1	5' 8"	5' 8"
1	14' 8"	14' 8"	1	4' 7"	4' 7"
1	14' 4"	14' 4"	1	4' 5"	4' 5"
1	13' 3"	13' 3"	1	4' 2"	4' 2"
1	12' 10"	12' 10"	1	3' 1"	3' 1"
1	11' 9"	11' 9"	1	3' 0"	3' 0"
1	11' 5"	11' 5"			
<b>SubTotal</b>	29	Panels			335' 5"

**Minimum Panel Length Breakdown**

- 1 / 4' 5" above made up of 1/2' 9", 1/1' 8".
- 1 / 3' above made up of 1/1' 3".

# Estimate For



**New Mart Builders Inc.**

1000 Cycle Lane  
 South Hill VA 23970  
 Email: bob.davis@newmartbuilder.com  
 Phone: 434-584-0027  
 Date: 16 December 2016



## Roof Take-Off

Job: TCD Summerwood

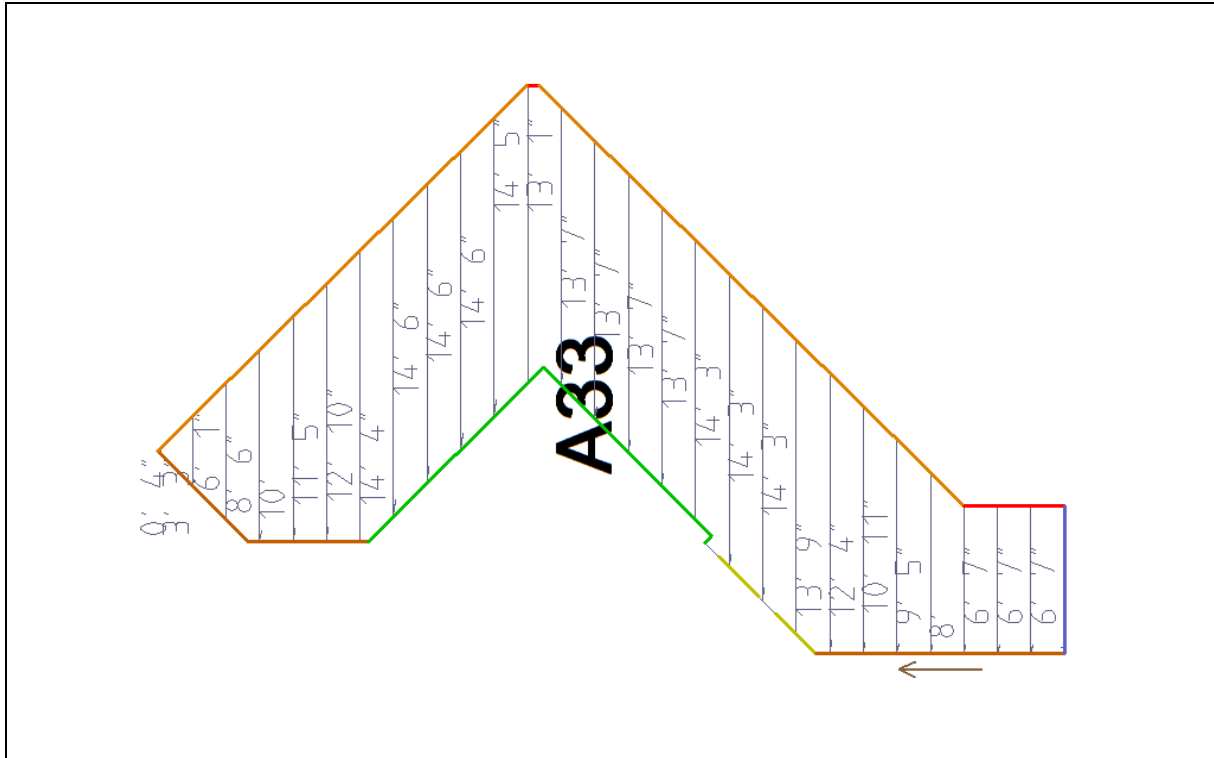

Plane A33 - 369.23 Sq. Ft.

Qty	Linear Feet	Total Lin. Feet	Qty	Linear Feet	Total Lin. Feet
3	14' 6"	43' 6"	1	10' 11"	10' 11"
1	14' 5"	14' 5"	1	10' 0"	10' 0"
1	14' 4"	14' 4"	1	9' 5"	9' 5"
3	14' 3"	42' 9"	1	8' 6"	8' 6"
1	13' 9"	13' 9"	1	8' 0"	8' 0"
4	13' 7"	54' 4"	3	6' 7"	19' 9"
1	13' 1"	13' 1"	1	6' 1"	6' 1"
1	12' 10"	12' 10"	1	3' 3"	3' 3"
1	12' 4"	12' 4"	1	3' 0"	3' 0"
1	11' 5"	11' 5"			
<b>SubTotal</b>	28	Panels			311' 8"

### Minimum Panel Length Breakdown

1 / 3' above made up of 1/0' 4".

# Estimate For



**New Mart Builders Inc.**

1000 Cycle Lane  
 South Hill VA 23970  
 Email: bob.davis@newmartbuilder.com  
 Phone: 434-584-0027  
**Date: 16 December 2016**



## Roof Take-Off

**Job: TCD Summerwood**

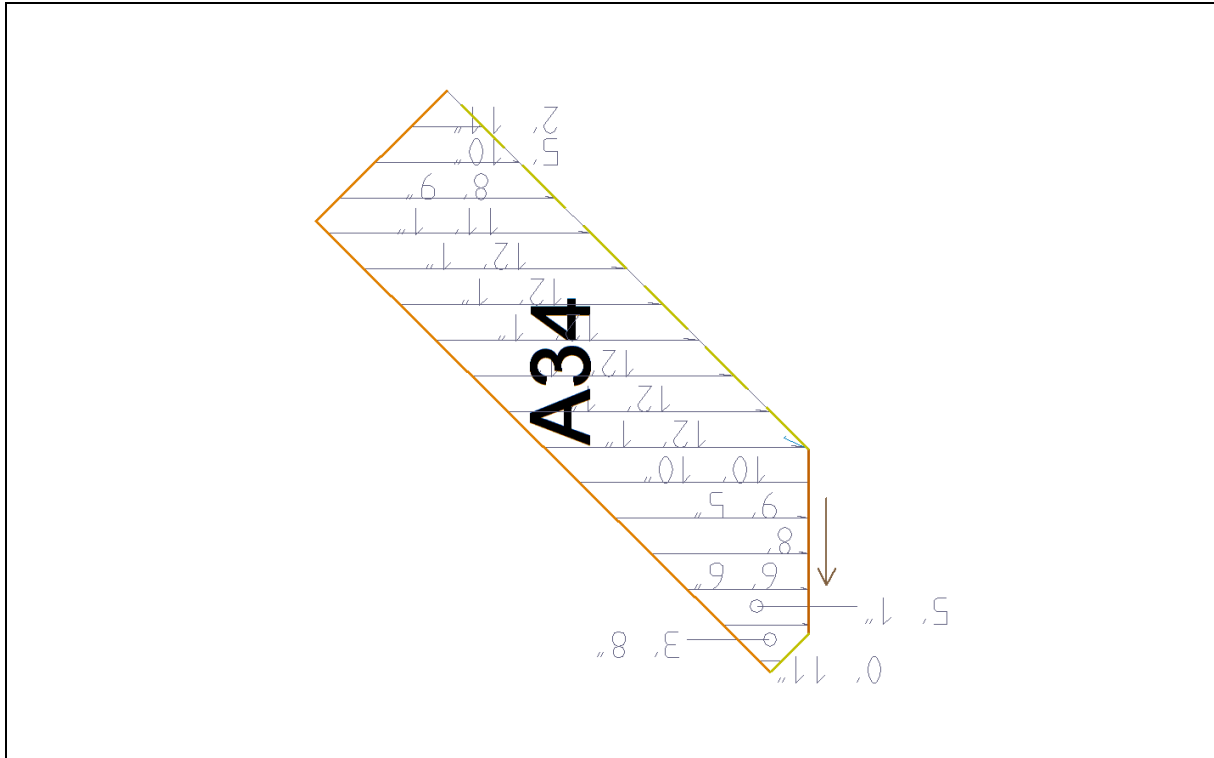

Plane A34 - 165.29 Sq. Ft.

Qty	Linear Feet	Total Lin. Feet	Qty	Linear Feet	Total Lin. Feet
6	12' 1"	72' 6"	1	6' 6"	6' 6"
1	11' 1"	11' 1"	1	5' 10"	5' 10"
1	10' 10"	10' 10"	1	5' 1"	5' 1"
1	9' 5"	9' 5"	1	3' 10"	3' 10"
1	8' 9"	8' 9"	1	3' 8"	3' 8"
1	8' 0"	8' 0"			
<b>SubTotal</b>	16	Panels			145' 6"

**Minimum Panel Length Breakdown**

1 / 3' 10" above made up of 1/2' 11", 1/0' 11".

# Estimate For



**New Mart Builders Inc.**

1000 Cycle Lane  
 South Hill VA 23970  
 Email: bob.davis@newmartbuilder.com  
 Phone: 434-584-0027  
**Date: 16 December 2016**



## Roof Take-Off

**Job: TCD Summerwood**

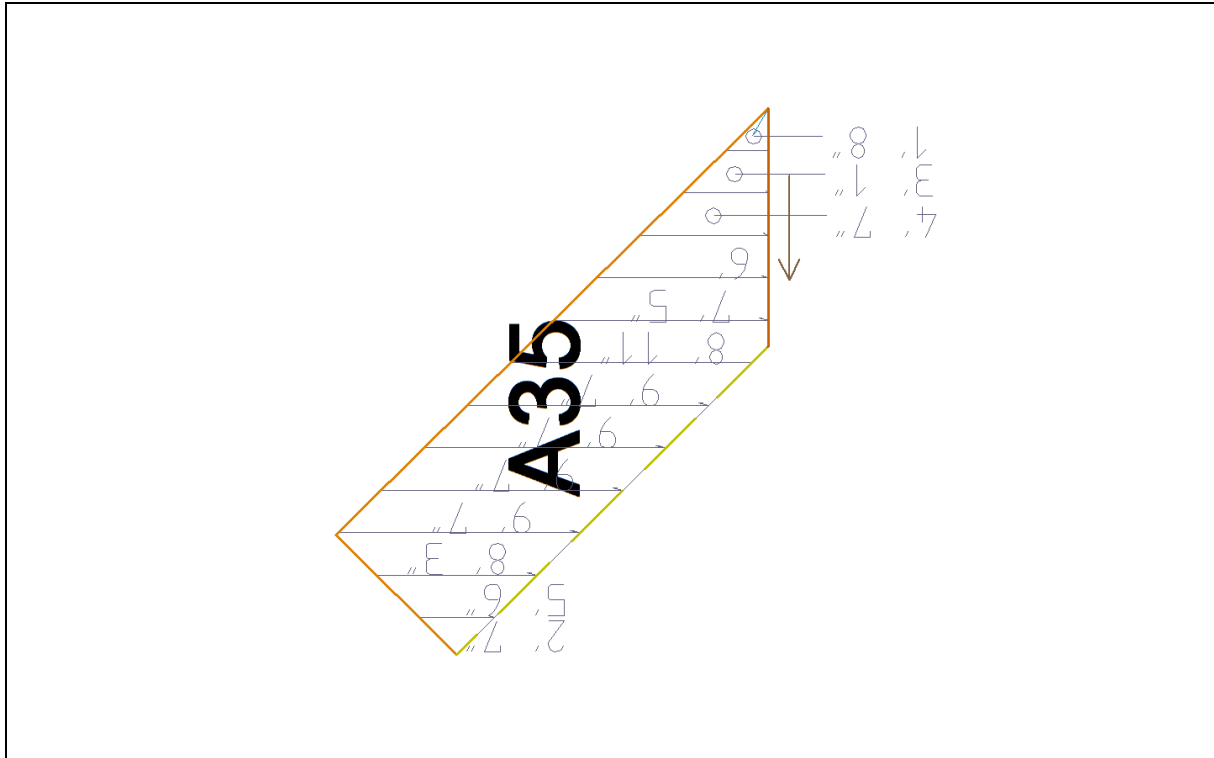

Plane A35 - 93.78 Sq. Ft.

Qty	Linear Feet	Total Lin. Feet	Qty	Linear Feet	Total Lin. Feet
4	9' 7"	38' 4"	1	5' 6"	5' 6"
1	8' 11"	8' 11"	1	4' 7"	4' 7"
1	8' 3"	8' 3"	1	4' 3"	4' 3"
1	7' 5"	7' 5"	1	3' 1"	3' 1"
1	6' 0"	6' 0"			
<b>SubTotal</b>	12	Panels			86' 4"

**Minimum Panel Length Breakdown**

1 / 4' 3" above made up of 1/2' 7", 1/1' 8".

# Estimate For



**New Mart Builders Inc.**

1000 Cycle Lane  
 South Hill VA 23970  
 Email: bob.davis@newmartbuilder.com  
 Phone: 434-584-0027  
**Date: 16 December 2016**



## Roof Take-Off

**Job: TCD Summerwood**

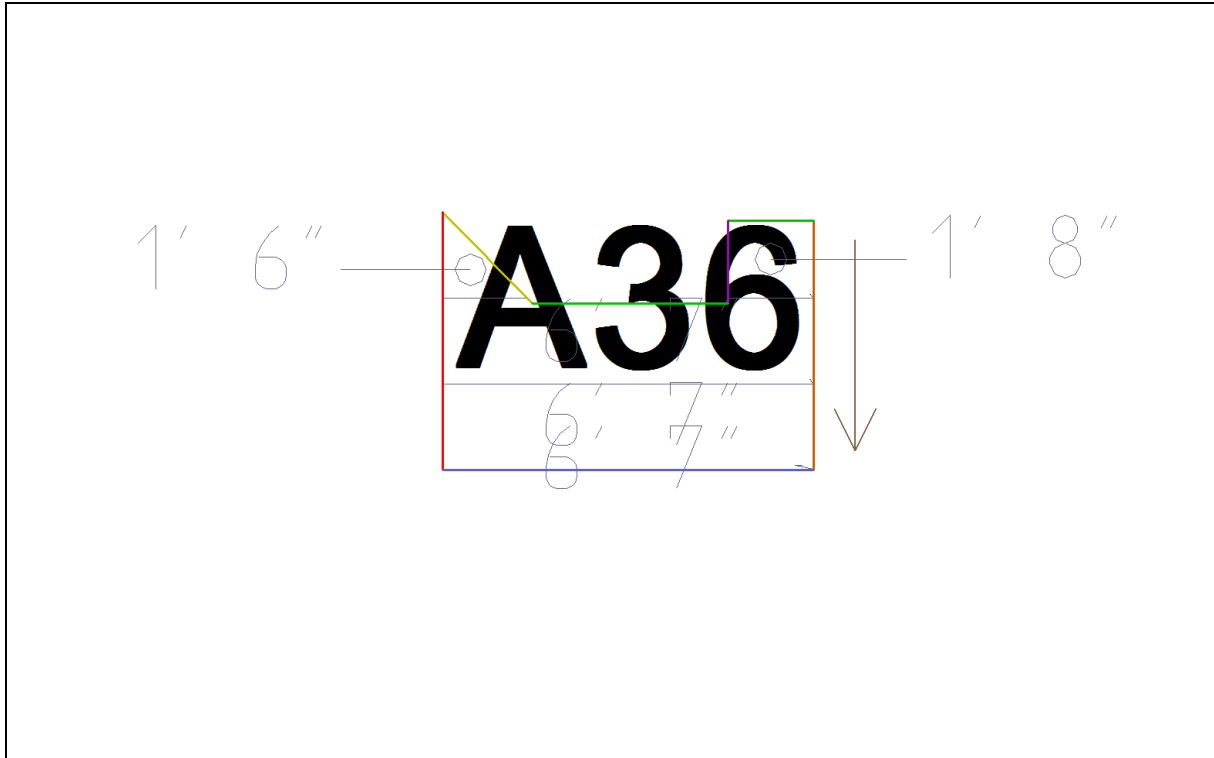

Plane A36 - 19.51 Sq. Ft.

Qty	Linear Feet	Total Lin. Feet	Qty	Linear Feet	Total Lin. Feet
3	6' 7"	19' 9"	1	3' 2"	3' 2"
<b>SubTotal</b>	4	Panels			22' 11"

**Minimum Panel Length Breakdown**

1 / 3' 2" above made up of 1/1' 8", 1/1' 6".

# Estimate For



**New Mart Builders Inc.**

1000 Cycle Lane  
 South Hill VA 23970  
 Email: bob.davis@newmartbuilder.com  
 Phone: 434-584-0027  
**Date: 16 December 2016**



## Roof Take-Off

**Job: TCD Summerwood**

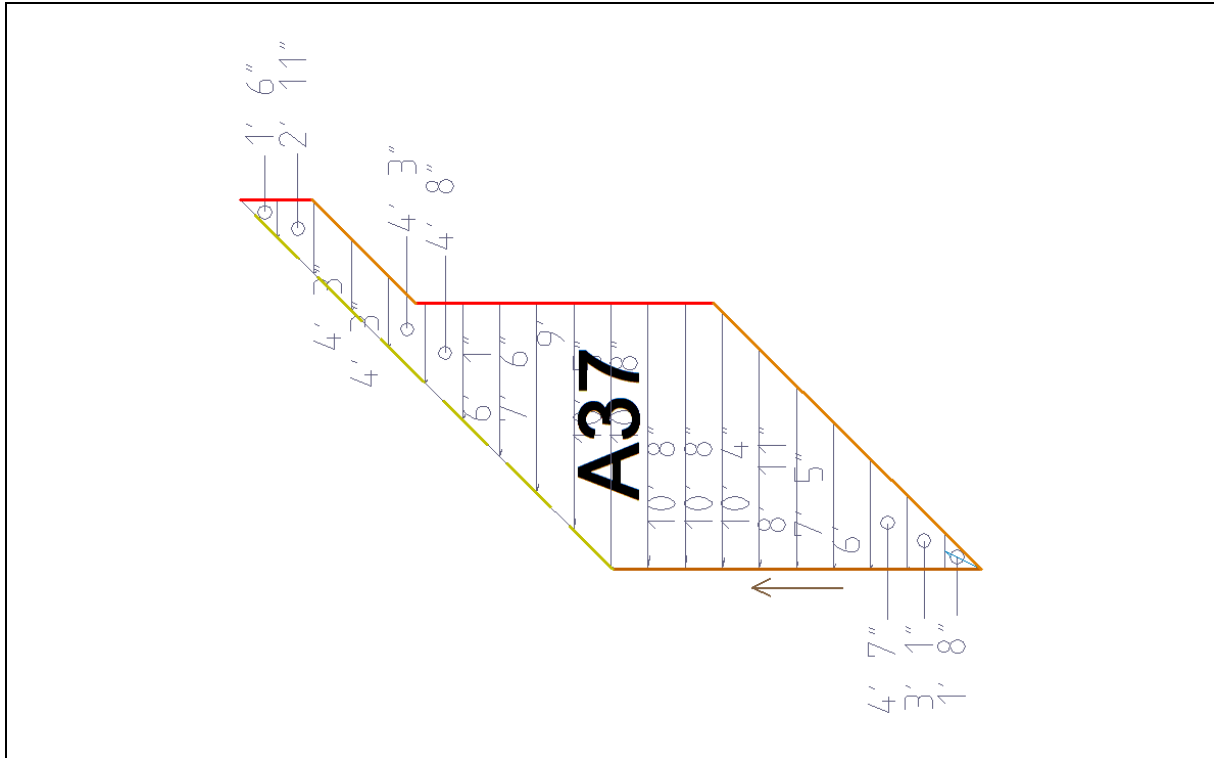

Plane A37 - 149.25 Sq. Ft.

Qty	Linear Feet	Total Lin. Feet	Qty	Linear Feet	Total Lin. Feet
3	10' 8"	32' 0"	1	6' 1"	6' 1"
1	10' 5"	10' 5"	1	6' 0"	6' 0"
1	10' 4"	10' 4"	1	4' 8"	4' 8"
1	9' 0"	9' 0"	2	4' 7"	9' 2"
1	8' 11"	8' 11"	3	4' 3"	12' 9"
1	7' 6"	7' 6"	1	3' 1"	3' 1"
1	7' 5"	7' 5"	1	3' 0"	3' 0"
<b>SubTotal</b>	19	Panels			130' 4"

**Minimum Panel Length Breakdown**

- 1 / 4' 7" above made up of 1/2' 11", 1/1' 8".
- 1 / 3' above made up of 1/1' 6".

# Estimate For



**New Mart Builders Inc.**

1000 Cycle Lane  
 South Hill VA 23970  
 Email: bob.davis@newmartbuilder.com  
 Phone: 434-584-0027  
 Date: 16 December 2016



## Roof Take-Off

Job: TCD Summerwood

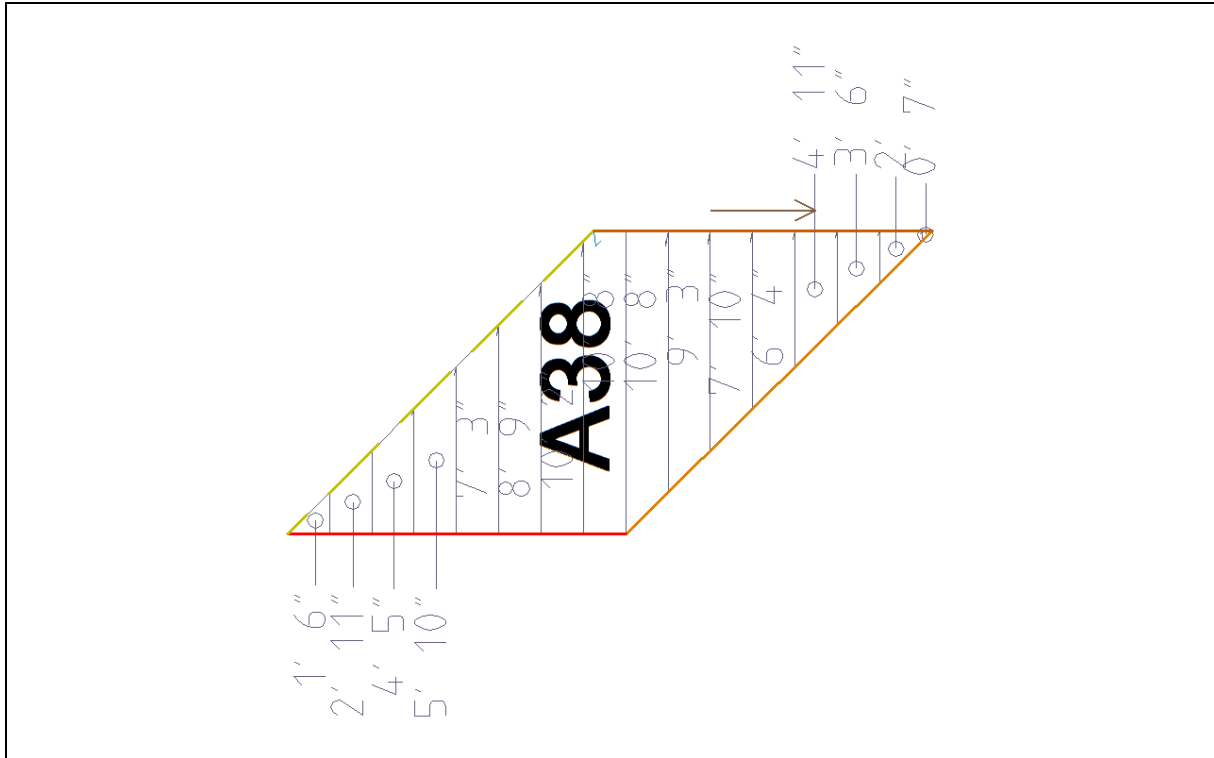

Plane A38 - 111.70 Sq. Ft.

Qty	Linear Feet	Total Lin. Feet	Qty	Linear Feet	Total Lin. Feet
2	10' 8"	21' 4"	1	6' 4"	6' 4"
1	10' 2"	10' 2"	1	5' 10"	5' 10"
1	9' 3"	9' 3"	2	4' 11"	9' 10"
1	8' 9"	8' 9"	1	4' 5"	4' 5"
1	7' 10"	7' 10"	1	3' 6"	3' 6"
1	7' 3"	7' 3"	1	3' 0"	3' 0"
<b>SubTotal</b>	14	Panels			97' 6"

**Minimum Panel Length Breakdown**

1 / 4' 11" above made up of 1/2' 11", 1/2'.

1 / 3' above made up of 1/1' 6", 1/0' 7".



# Estimate For



**New Mart Builders Inc.**

1000 Cycle Lane  
 South Hill VA 23970  
 Email: bob.davis@newmartbuilder.com  
 Phone: 434-584-0027  
**Date: 16 December 2016**



## Roof Take-Off

**Job: TCD Summerwood**

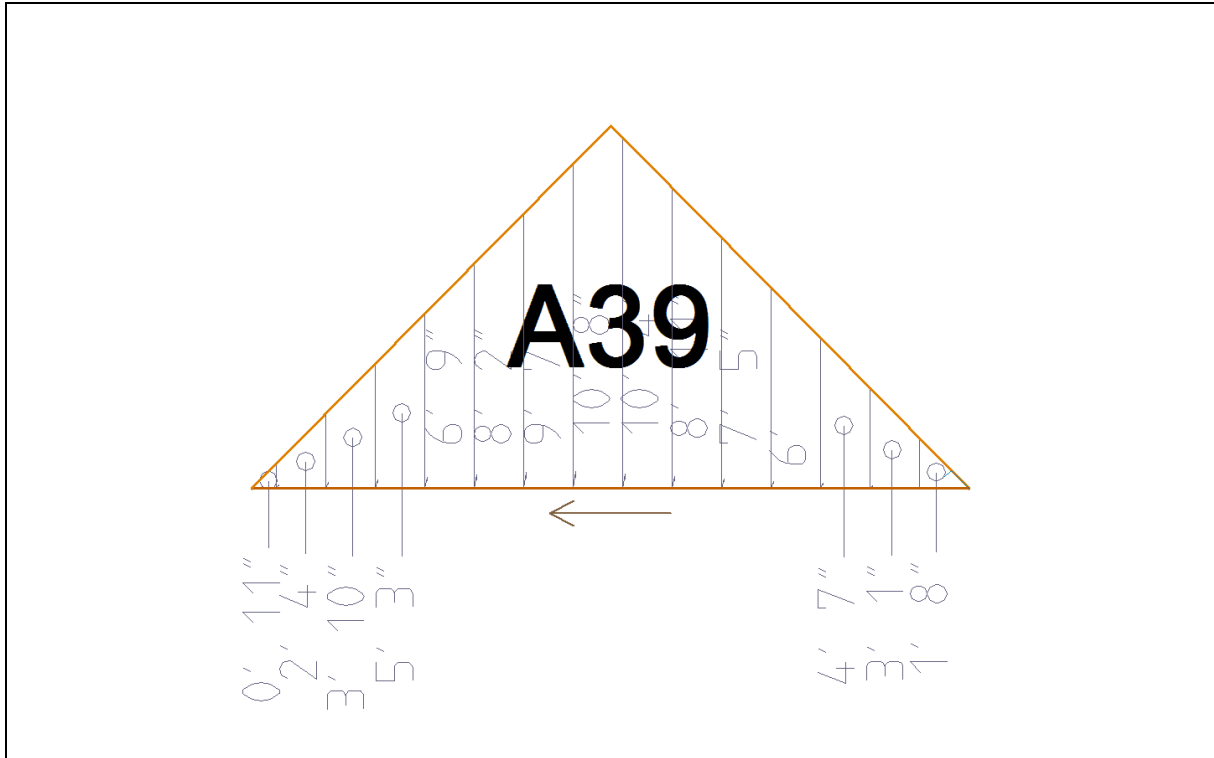

Plane A39 - 101.23 Sq. Ft.

Qty	Linear Feet	Total Lin. Feet	Qty	Linear Feet	Total Lin. Feet
1	10' 8"	10' 8"	1	6' 0"	6' 0"
1	10' 4"	10' 4"	1	5' 3"	5' 3"
1	9' 7"	9' 7"	1	4' 7"	4' 7"
1	8' 11"	8' 11"	1	4' 0"	4' 0"
1	8' 2"	8' 2"	1	3' 10"	3' 10"
1	7' 5"	7' 5"	1	3' 1"	3' 1"
1	6' 9"	6' 9"	1	3' 0"	3' 0"
<b>SubTotal</b>	14	Panels			91' 7"

**Minimum Panel Length Breakdown**

- 1 / 4' 0" above made up of 1/2' 4", 1/1' 8".
- 1 / 3' above made up of 1/0' 11".

# Estimate For



**New Mart Builders Inc.**

1000 Cycle Lane  
 South Hill VA 23970  
 Email: bob.davis@newmartbuilder.com  
 Phone: 434-584-0027  
**Date: 16 December 2016**



## Roof Take-Off

**Job: TCD Summerwood**

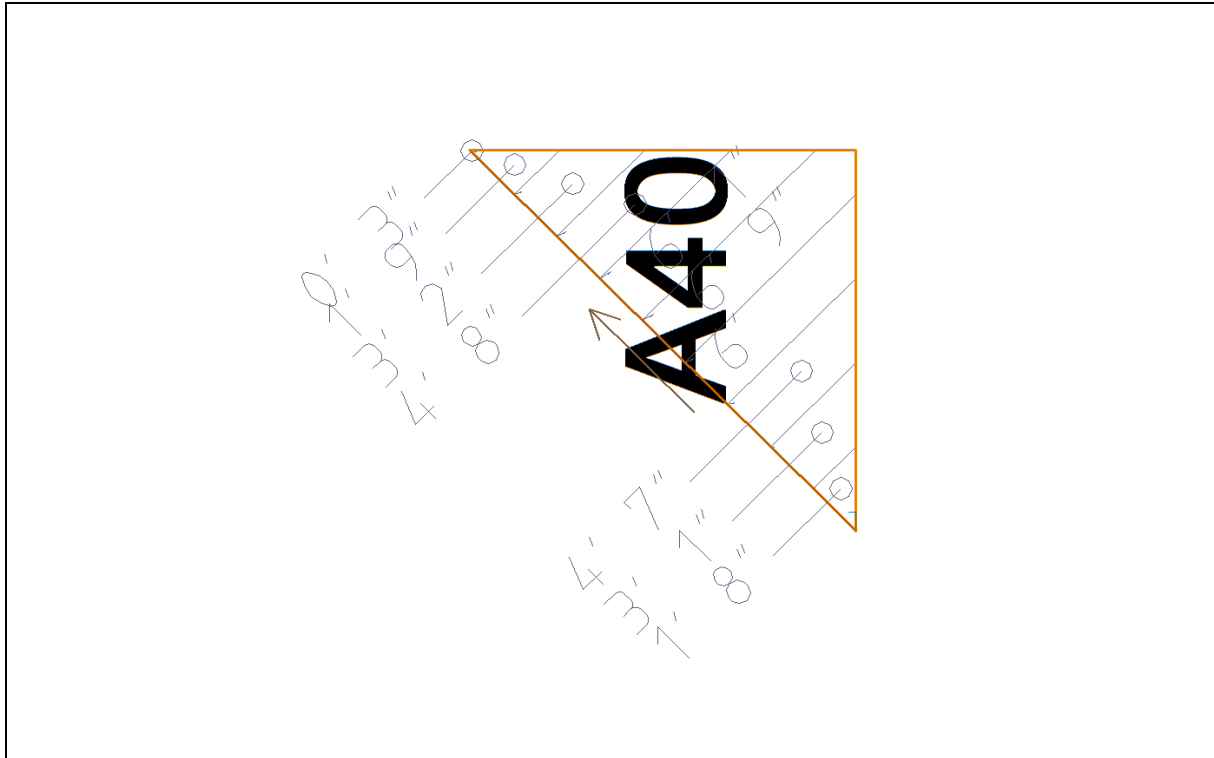

Plane A40 - 39.54 Sq. Ft.

Qty	Linear Feet	Total Lin. Feet	Qty	Linear Feet	Total Lin. Feet
1	6' 9"	6' 9"	1	3' 5"	3' 5"
1	6' 1"	6' 1"	1	3' 2"	3' 2"
1	6' 0"	6' 0"	1	3' 1"	3' 1"
1	4' 8"	4' 8"	1	3' 0"	3' 0"
1	4' 7"	4' 7"			
<b>SubTotal</b>	9	Panels			40' 9"

**Minimum Panel Length Breakdown**

- 1 / 3' 5" above made up of 1/1' 9", 1/1' 8".
- 1 / 3' above made up of 1/0' 4".

# Estimate For



**New Mart Builders Inc.**

1000 Cycle Lane  
 South Hill VA 23970  
 Email: bob.davis@newmartbuilder.com  
 Phone: 434-584-0027  
**Date: 16 December 2016**



## Roof Take-Off

**Job: TCD Summerwood**

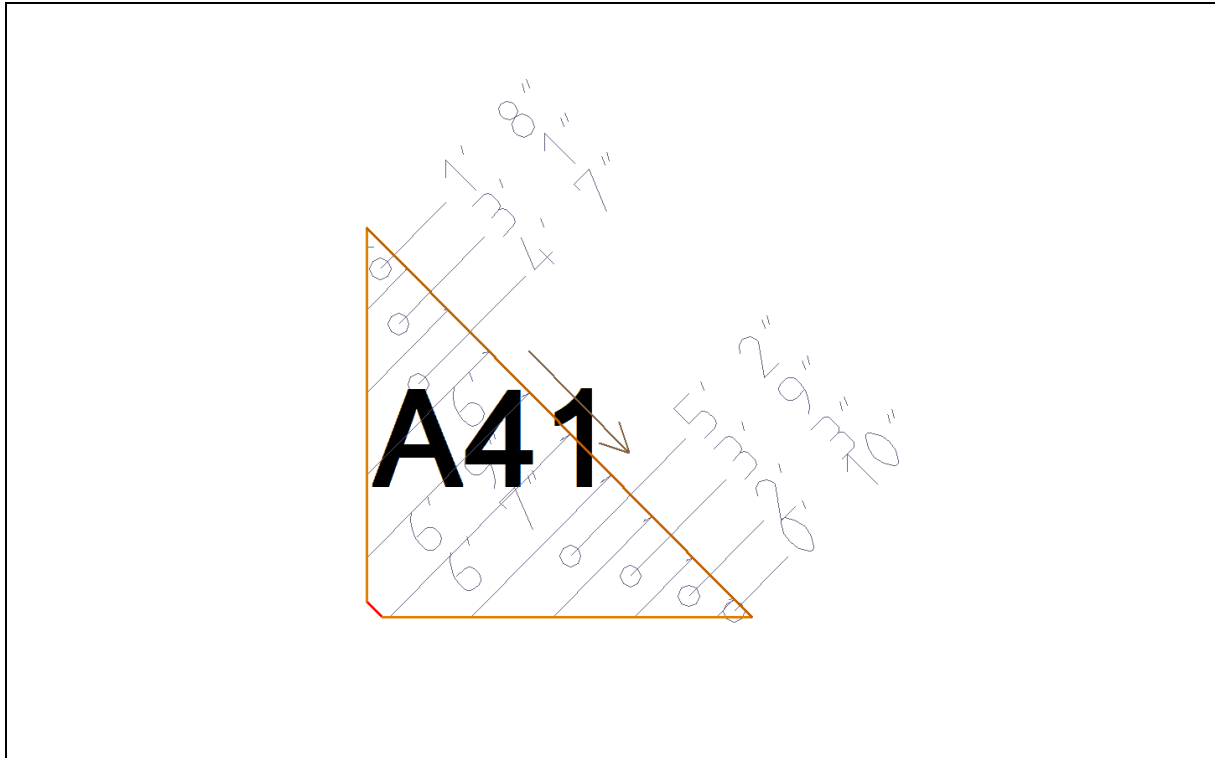

Plane A41 - 42.82 Sq. Ft.

Qty	Linear Feet	Total Lin. Feet	Qty	Linear Feet	Total Lin. Feet
1	6' 9"	6' 9"	1	3' 11"	3' 11"
1	6' 7"	6' 7"	1	3' 9"	3' 9"
1	6' 0"	6' 0"	1	3' 1"	3' 1"
1	5' 2"	5' 2"	1	3' 0"	3' 0"
1	4' 7"	4' 7"			
<b>SubTotal</b>	9	Panels			42' 10"

**Minimum Panel Length Breakdown**

1 / 3' 11" above made up of 1/2' 3", 1/1' 8".

1 / 3' above made up of 1/0' 10".

# Estimate For



**New Mart Builders Inc.**

1000 Cycle Lane  
 South Hill VA 23970  
 Email: bob.davis@newmartbuilder.com  
 Phone: 434-584-0027  
**Date: 16 December 2016**



## Roof Take-Off

**Job: TCD Summerwood**

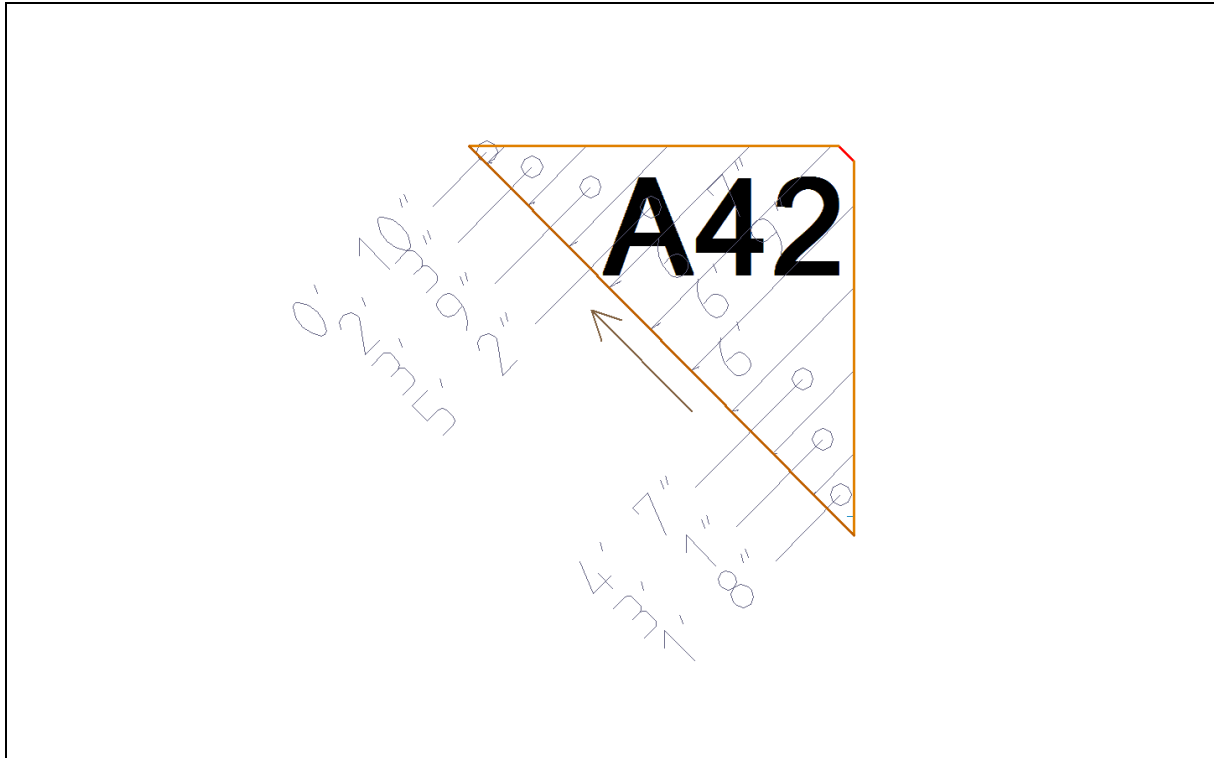

Plane A42 - 42.82 Sq. Ft.

Qty	Linear Feet	Total Lin. Feet	Qty	Linear Feet	Total Lin. Feet
1	6' 9"	6' 9"	1	3' 11"	3' 11"
1	6' 7"	6' 7"	1	3' 9"	3' 9"
1	6' 0"	6' 0"	1	3' 1"	3' 1"
1	5' 2"	5' 2"	1	3' 0"	3' 0"
1	4' 7"	4' 7"			
<b>SubTotal</b>	9	Panels			42' 10"

**Minimum Panel Length Breakdown**

1 / 3' 11" above made up of 1/2' 3", 1/1' 8".

1 / 3' above made up of 1/0' 10".

# Estimate For



**New Mart Builders Inc.**

1000 Cycle Lane  
 South Hill VA 23970  
 Email: bob.davis@newmartbuilder.com  
 Phone: 434-584-0027  
**Date: 16 December 2016**



## Roof Take-Off

**Job: TCD Summerwood**

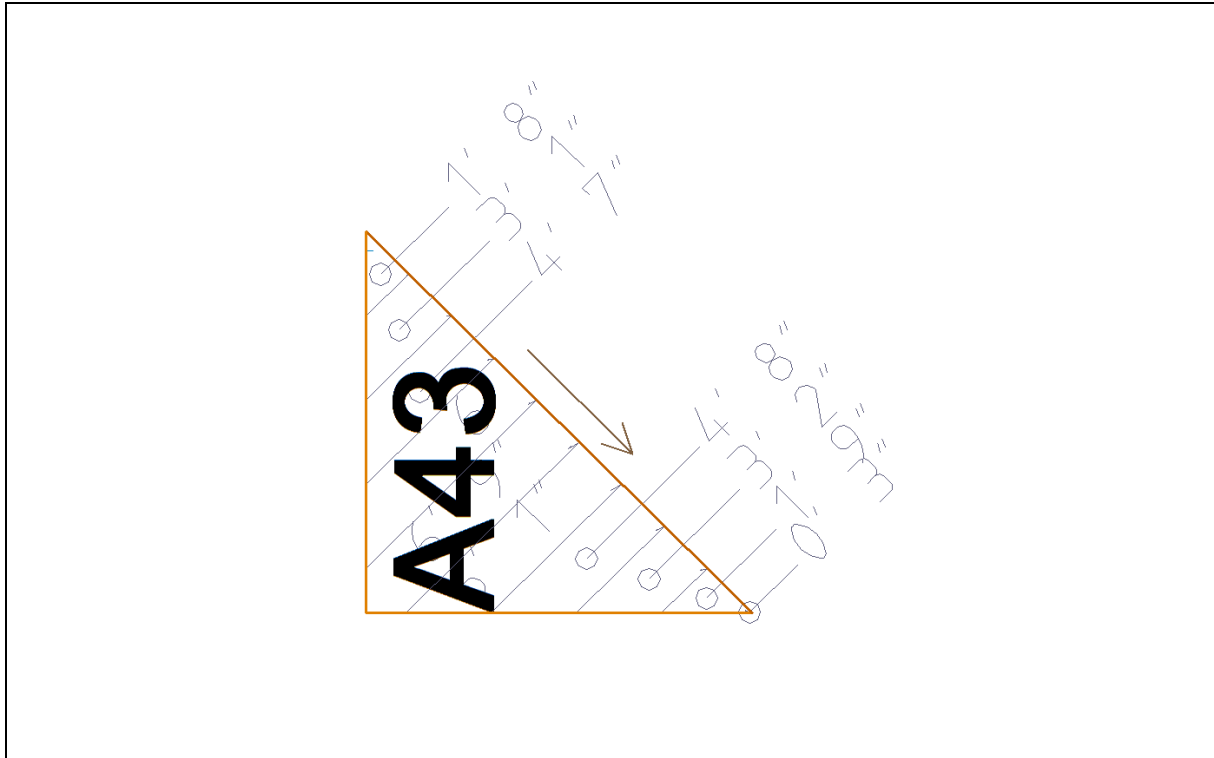

Plane A43 - 39.54 Sq. Ft.

Qty	Linear Feet	Total Lin. Feet	Qty	Linear Feet	Total Lin. Feet
1	6' 9"	6' 9"	1	3' 5"	3' 5"
1	6' 1"	6' 1"	1	3' 2"	3' 2"
1	6' 0"	6' 0"	1	3' 1"	3' 1"
1	4' 8"	4' 8"	1	3' 0"	3' 0"
1	4' 7"	4' 7"			
<b>SubTotal</b>	9	Panels			40' 9"

**Minimum Panel Length Breakdown**

- 1 / 3' 5" above made up of 1/1' 9", 1/1' 8".
- 1 / 3' above made up of 1/0' 4".